



BOSCH

Invented for life

Bosch HBF011BA0

Series | 2 Built-in oven 60 x 60 cm Black

Main Features:

- 5 cooking programs: HotAir 3D MultiCooking, Upper and lower heating, Ventilated grill
- Temperature regulation from 50 °C to 270 °C
- Cavity volume: 66 l

Other characteristics:

- Mechanical minute timer (acoustic signal only)
- Fast heating
- Internal halogen lighting
- Tangential cooling fan

Power & Consumption:

- Maximum electrical absorption: 2.99 kW
- Energy efficiency class (acc. EU Nr. 65/2014): A (on a scale of energy efficiency classes from A +++ to D)
- Energy consumption per cycle during conventional operation: 0.98 kWh
- Energy consumption per cycle during ventilated operation: 0.79 kWh
- Number of cavities: 1
- Type of power supply: electric

Technical data:

- Product size 595 x 594 x 548 mm
- Niche dimensions (HxWxD): 560 mm - 568 mm x 575 mm - 597 mm x 550 mm

Length of the power supply cable: 100 cm

Voltage: 220-240V

Power: 2,990 W

Current: 16 A

Guarantee: 5 years parts and labour

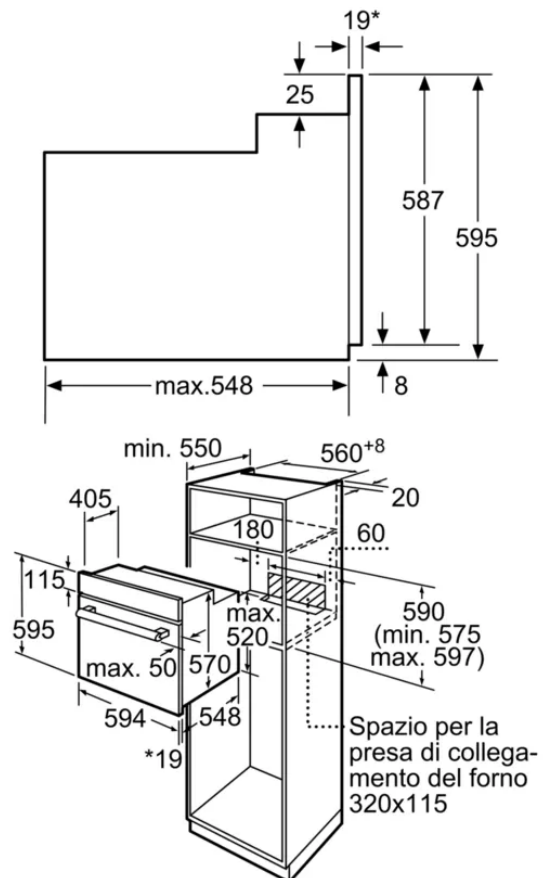

* 20 mm per parte frontale in metallo

