

N 70, Built-in oven with added steam function, 60 x 60 cm,
Graphite-Grey
B47VR22G0



A+



Built-in oven with Vario Steam and Slide&Hide® - fuller flavour and unrestricted access to the oven interior thanks to the fully retracting oven door with rotating handle

- ✓ Slide&Hide® - the door disappears underneath the oven for unrestricted access and the handle rotates for easy handling
- ✓ Circo Therm® - our smart hot-air solution for simultaneous baking and roasting on up to four levels
- ✓ Vario Steam - steam assistance that cooks food moist on the inside and crisp on the outside
- ✓ Eco Clean with Easy Clean - the duo that makes oven cleaning easier
- ✓ ShiftControl - fast navigation through menus and simple operation with the TFT display

Features

Technical Data

Color / Material Front : Graphite
 Built-in / Free-standing : Built-in
 Integrated Cleaning system : Catalytic partial, Hydrolytic
 Min. required niche size for installation (HxWxD) : 585-595 x 560-568 x 550 mm
 Dimensions : 595 x 596 x 548 mm
 Dimensions of the packed product (HxWxD) : 675 x 690 x 660 mm
 Control Panel Material : Glass
 Door Material : Glass
 Net weight : 39.4 kg
 Usable volume of cavity : 71 l
 Heating modes : , 4D hot air, Bottom heat, Bread Baking Setting, Full width grill, Gentle heating, Half width grill, Hot Air-Eco, Hot air grilling, Keep warm, Pizza setting, Regeneration, Top/bottom heat
 Oven control : electronic
 Number of interior lights : 1
 Length electrical supply cord : 120.0 cm
 EAN code : 4242004255345
 Number of cavities (2010/30/EC) : 1
 Energy efficiency class (2010/30/EC) : A+
 Energy consumption per cycle conventional (2010/30/EC) : 0.87 kWh/cycle
 Energy consumption per cycle forced air convection (2010/30/EC) : 0.69 kWh/cycle
 Energy efficiency index (2010/30/EC) : 81.2 %
 Connection Rating : 3600 W
 Fuse protection : 16 A
 Voltage : 220-240 V
 Frequency : 50; 60 Hz
 Plug type : Gardy plug w/ earthing
 Included accessories : 1 x enamel baking tray, 1 x combination grid, 1 x universal pan

Optional accessories

Z11AB15A0 : Baking tray, non-stick ceramic coated , Z11AU15A0 : Universal pan, non-stick ceramic coated , Z11CG10X0 : Barbecue-Set , Z11CR10X0 : Baking and roasting grid (standard) , Z11GT10X3 : Glass roasting dish, 5,4l , Z11GU20X0 : Glasspan , Z11SZ00X0 : SeamlessCombination mounting kit , Z11SZ90G0 : SeamlessCombination 60 + 45cm , Z11TC10X0 : ComfortFlex Rail (1 level) , Z11TC16X0 : ComfortFlex Rail (1 level) and racks , Z11TF36X0 : 3 level telescopic rails, full ext , Z12CB10A0 : Baking tray, anthracite enamelled , Z12CL10A0 : Lid for professional pan, enamelled anth , Z12CM10A0 : Moussaka pan, anthracite enamelled , Z12CN10A0 : Professional pan, anthracite enamelled , Z12CP10A0 : Pizza pan, anthracite enamelled , Z12CQ10A0 : Grill tray, anthracite enamelled , Z12CU10A0 : Multipurpose pan, anthracite enamelled , Z13CR10X0 : Baking and roasting grid (steam) , Z1913X0 : Baking Stone , Z19DD10X0 : Steam set for ovens , Z99RX70X0 : Connecting cable 3m



4 242004 255345

*N 70, Built-in oven with added steam function, 60
x 60 cm, Graphite-Grey
B47VR22G0*

Features

Type of oven / heating system:

- Oven with 12 heating methods: CircoTherm®, Hotair Eco, Conventional heat, Conventional heat ECO, Hot air grilling, Full surface grill, Half width grill, Pizza setting, Bread Baking, Bottom heat, Low temperature cooking, Keep warm
- Additional heating methods with steam: Regeneration with steam, Fermentation with steam
- Temperature range 40 °C - 275 °C
- Cavity volume: 71 l

Hook-in racks / rails

- Number of shelf levels: 4 PC
- Telescopic shelf rails as optional accessory

Design:

- Graphite-Grey Edition
- Cavity inner surface: enamel

Cleaning:

- Eco Clean: coating of back panel
- Easy Clean (program)
- Full glass inner door - safer touch door

Comfort:

- 2,5"-TFT- color and text display with touch-control buttons
- Electronic clock
- Temperature proposal
Actual temperature display Optical temperature control
- Number of automatic programmes: 18 PC
- Additional functions:
descaling programme
Steam cooking function (only when using steam-set) drying function
- Hide®, the fully retracting oven door
- Slide®, the revolving handle
- Supporting systems: Programs
- Rapid heat
- LED light, Independent oven interior light button
- Water tank empty indicator
- Location of the steam generator is outside of the cavity
- Cooling fan
- Stainless-steel fan

Accessory:

- 1 x enamel baking tray, 1 x combination grid, 1 x universal pan

Environment and Safety:

- Low door temperature
- Triple glazed door glazed CoolTouch door
- Individual adjustable child lock
Residual heat indicator Start-/Stop button Door contact switch

Technical Information

- Length of mains cable: 120 cm
- Nominal voltage: 220 - 240 V
- Total connected load electric: 3.6 KW
- Energy efficiency rating (acc. EU Nr. 65/2014): A+(at a range of energy efficiency classes from A+++ to D)
Energy consumption per cycle in conventional mode:0.87 kWh
Energy consumption per cycle in fan-forced convection mode:0.69 kWh
Number of cavities: 1 Heat source: electrical Cavity volume:71 l

Dimensions:

- Appliance dimension (HxWxD): 595 mm x 596 mm x 548 mm
- Niche dimension (HxWxD): 585 mm - 595 mm x 560 mm - 568 mm x 550 mm
- "Please reference the built-in dimensions provided in the installation drawing"
- We recommend you to choose complementary products within N70, in order to assure an optimal design combination of your Built-In appliances.

N 70, Built-in oven with added steam function, 60 x 60 cm, Graphite-Grey
B47VR22G0

Dimensioned drawings

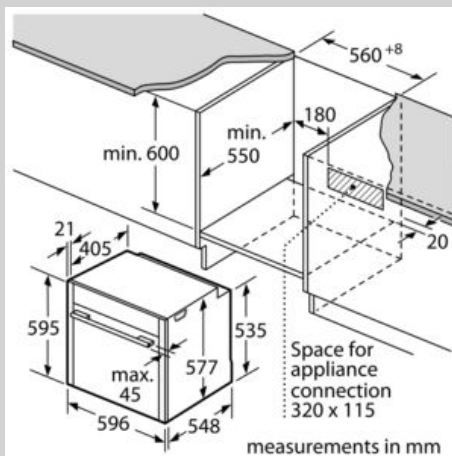
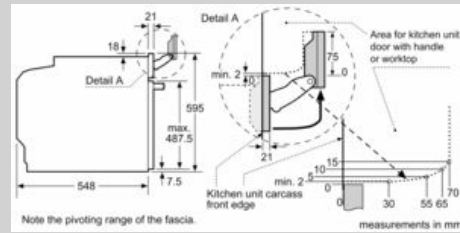
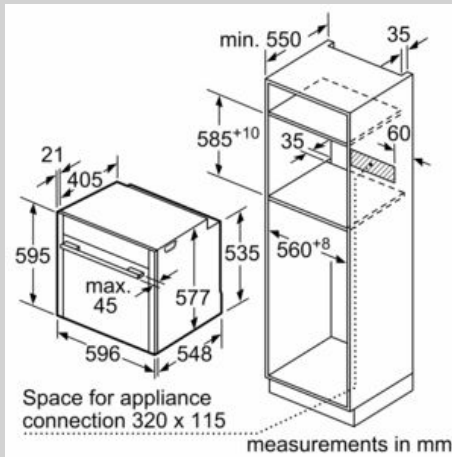

If the appliance will be installed underneath a hob, the following worktop thicknesses (including substructure if necessary) must be taken into account.

Hob type	min. worktop thickness	
	fitted	flush
Induction hob	37 mm	38 mm
Full surface Induction hob	47 mm	48 mm
Gas hob	30 mm	38 mm
Electric hob	27 mm	30 mm

