

Series 4, free-standing fridge-freezer with freezer at bottom, 203 x 70 cm, Stainless steel (with anti-fingerprint) KGN497ICT



The No Frost bottom freezer with VitaFresh and XXL capacity: Keeps your fresh foods fresh for longer

- **XXL capacity:** provides lots of space for your food.
- **VitaFresh XXL <0°C>:** keeps food fresh for longer in extra-large climate-controlled fridge drawers.
- **No Frost:** you'll never have to defrost your fridge-freezer again.
- **Glossy Backwall with Multi Airflow:** evenly circulates fresh air to maintain consistent temperatures.
- **Flex Shelf:** space for bottles and bowls with sectioned glass shelves that can be separated and slid underneath or fold up to the backwall.

Technical Data

Energy Efficiency Class (Regulation (EU) 2017/1369): C
 Average annual energy consumption in kilowatt hour per year (kWh/a): 178 kWh/annum
 Sum of volume of frozen compartments: 129 l
 Sum of volume of chill compartments: 311 l
 Airborne acoustical noise emissions : 35 dB(A) re 1 pW
 Airborne acoustical noise emission class: B
 Built-in / Free-standing: Free-standing
 Door panel options: Not possible
 Height: 2030 mm
 Width of the appliance: 700 mm
 Depth of the product: 667 mm
 Net weight: 81.5 kg
 Fuse protection: 10 A
 Door hinge: Right reversible
 Voltage: 220-240 V
 Length electrical supply cord: 240.0 cm
 Number of compressors: 1
 Number of independent cooling systems: 2
 Interior ventilator: No
 Reversible Door Hinge: Yes
 Number of Adjustable Shelves in fridge compartment: 3
 Shelves for Bottles: Yes
 Installation typology: N/A



Included accessories

3 x egg tray
 1 x ice cube tray

Optional accessories

KSZ39AL00 : Connection set inox



Series 4, free-standing fridge-freezer with freezer at bottom, 203 x 70 cm, Stainless steel (with anti-fingerprint) KGN497ICT

The No Frost bottom freezer with VitaFresh and XXL capacity: Keeps your fresh foods fresh for longer

- Total NoFrost - never defrost again, Bottom freezer
- inox EasyClean Doors

Performance and consumption

- Energy Class: C
- Total Volume: 440 l
- Net Fridge Volume : 311 l
- Net Freezer Volume : 129 l
- Freezing capacity 24h: 11 kg
- Annual Energy Consumption: 178 kWh/a
- Climate Class: SN-T
- Fast Freeze Facility
- Noise Level : 35 dB , B Class
- Temperature rise time : 18 H

Design and Styling

- Doors inox EasyClean, side panels Pearl grey (VZF 07127)
- White glossy backwall with Multi-Airflow
- vertical handle
- LED with Soft Start in fridge section

Convenience & Safety

- Total NoFrost - never defrost again
- Separate, electronic temperature control, LED indicators
- Two Cooling Systems
- Super Cooling: automatic deactivation
- Optical and acoustic door open warning system
- Visual and acoustic warning system in case of malfunction of the freezer compartment

Fridge Compartment

- Multi Airflow-System
- 5 safety glass shelves, thereof 3 height adjustable, Flex Shelf - dividable and foldable glass shelf
- 5 PC safety glass shelves of which 3 are height adjustable
- Bottle storage: Bottle grid
- 1 door bin(s) high, 3 door bin(s) small
- 4 door bins, thereof 1 door bin(s) high

Freshness System

- 1 VitaFresh ◀0°C▶ drawer - Fish and meat stay fresh for longer
- 1 VitaFresh drawer with humidity control - Fruits and vegetables retain vitamins and stay fresh for longer.

Freezer

- 3 transparent freezer drawers

Dimensions

- Appliance Dimensions (H x W x D): 203 cm x 70 cm x 66.7 cm

Technical Information

- Door right hinged, reversible
- Height adjustable front feet
- Length of power cord: 240 cm
- Nominal voltage: 220 - 240 V

Accessories

- egg tray
ice cube tray
- egg tray
ice cube tray

Country Specific Options

- Based on the results of the standard 24-hour test. Actual consumption depends on usage/position of the appliance.

Environment and Safety

Installation

General Information

- Super Freezing: Manual/automatic activation
- Compressor Technology: inverter compressor

**Series 4, free-standing fridge-freezer with freezer at bottom, 203 x 70 cm, Stainless steel (with anti-fingerprint)
KGN497ICT**

Measurements in mm

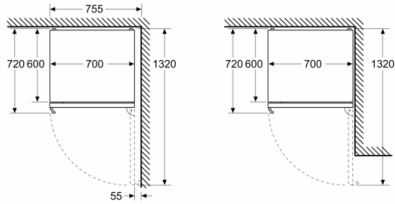

Measurements in mm

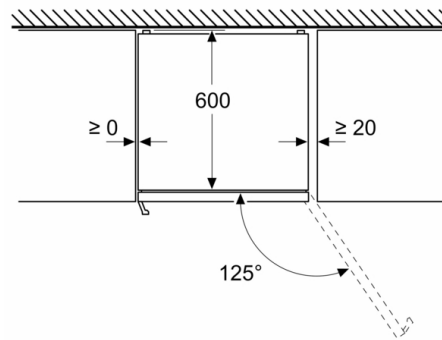

Measurements in mm

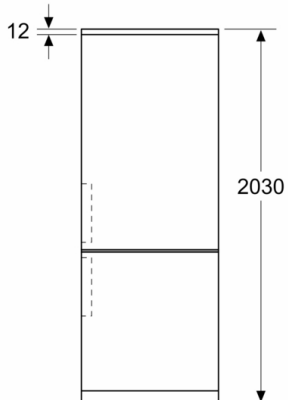

Measurements in mm

