

Series 2, built-in fridge-freezer with freezer at bottom, 177.2 x 54.1 cm, sliding hinge KIN865SE0



KSZB6R00 Bottle Rack
KSZGGM00 Butter box

The spacious built-in fridge-freezer combination with NoFrost provides optimal food storage and ice formation is no longer an issue.

- **Multi Box XXL:** extra-large drawer for your fruit and vegetables.
- **Eco Airflow:** optimal air circulation and even temperature level in the cooling area.
- **No Frost:** You'll never have to defrost your freezer again.
- **Door Open Alarm:** Reminds you if the door is not closed properly.
- **Made in Germany:** high quality standards and thorough testing for enduring satisfaction.

Energy Efficiency Class (Regulation (EU) 2017/1369): E
Average annual energy consumption in kilowatt hour per year (kWh/a): 234 kWh/annum
Sum of volume of frozen compartments: 76 l
Sum of volume of chill compartments: 184 l
Airborne acoustical noise emissions : 35 dB(A) re 1pW
Airborne acoustical noise emission class: B
Built-in / Free-standing: Built-in
Number of compressors: 1
Number of independent cooling systems: 1
Width of the appliance: 541 mm
Height: 1772 mm
Depth of the product: 548 mm
Net weight: 51.7 kg
Required niche size for installation (HxWxD):	... 1775 x 560 x 550 mm
Door panel options: Not possible
Door hinge: Right reversible
Number of Adjustable Shelves in fridge compartment: 3
Shelves for Bottles: No
No Frost free system: Freezer
Interior ventilator: No
Reversible Door Hinge: Yes
Length electrical supply cord: 230.0 cm
Multi-Flow Air Tower: No
Fast cooling switch: Yes
Fast freezing function: Yes
Temperature Controlled Drawer: No
Humidity Control Drawer: No
Number of Door Bins - Refrigerator: 3
Door bin adjustability - Refrigerator: Yes
Tilt-out door bins in fridge: No
Gallon wide door bins: Yes
Number of Gallon storage: 1
Motorized Shelf: No
Material of the shelves: Safety glass
Door opened indicator freezer: No
Automatic motor-driven ice-maker: No
Fuse protection: 10 A
Voltage: 220-240 V
Frequency: 50 Hz
Storage Period in Event of Power Failure (h): 10 h
Door panel options: Not possible
ENERGY STAR® certified: No
Plug type: GARDY plug w/ earthing
Required cutout/niche size for installation (in): x
Dimensions of the packed product: 72.45 x 24.01 x 25.19
Net weight: 114.000 lbs
Gross weight: 123.000 lbs

Series 2, built-in fridge-freezer with freezer at bottom, 177.2 x 54.1 cm, sliding hinge KIN865SE0

The spacious built-in fridge-freezer combination with NoFrost provides optimal food storage and ice formation is no longer an issue.

- ice cube tray

General Information

Environment and Safety

Installation

Performance and consumption

- Energy Class: E
- Total Volume: 260 l
- Annual Energy Consumption: 234 kWh/a
- Fast Freeze Facility
- Noise Level : 35 dB , B Class

Design and Styling

- LED interior light in fridge section

Convenience & Safety

- LED electronic control
- Super Cooling: automatic deactivation
- Automatic defrost in fridge section
- Optical and acoustic door open warning system

Fridge Compartment

- Net fridge volume: 184 l
- 4 PC safety glass shelves of which 3 are height adjustable
- 1 door bin(s) high, 2 door bin(s) small

Freshness System

- 1 MultiBox - Transparent drawer with a corrugated bottom, ideal for storing fruits and vegetables.

Freezer

- Net Freezer Volume : 76 l
- Freezing capacity 24h: 4 kg
- Temperature rise time : 10 H
- NoFrost
- Super Freezing: Manual/automatic activation
- 3 transparent freezer drawers

Dimensions

- Appliance Dimensions (H x W x D): 177.2 cm x 54.1 cm x 54.8 cm
- Niche Dimension (H x W x D): 177.5 cm x 56.0 cm x 55.0 cm

Technical Information

- Door right hinged, reversible
- Nominal voltage: 220 - 240 V
- Length of power cord: 230 cm
- Height adjustable front feet
- Climate Class: SN-ST

Country Specific Options

- Based on the results of the standard 24-hour test. Actual consumption depends on usage/position of the appliance.

Accessories

- ice cube tray

**Series 2, built-in fridge-freezer with
freezer at bottom, 177.2 x 54.1 cm,
sliding hinge
KIN865SE0**

measurements in mm

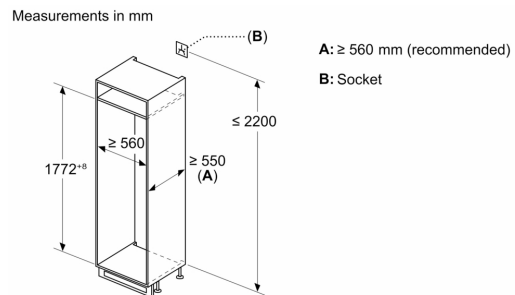
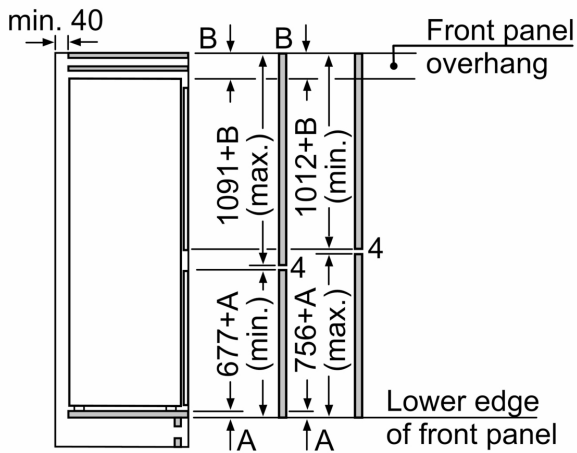
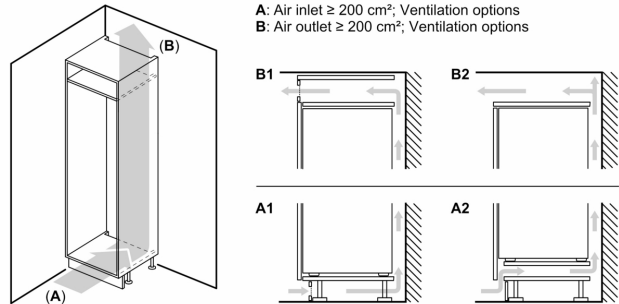
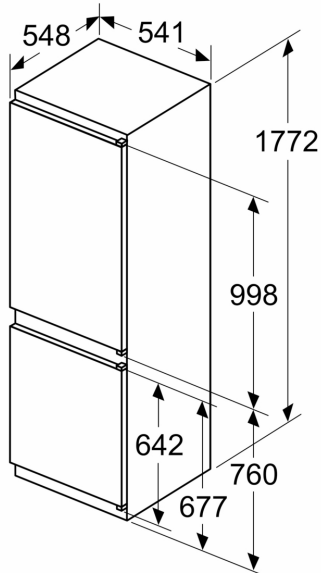

The specified unit door dimensions
are valid for a door gap of 4 mm.

measurements in mm