

Series 8, Built-In Microwave, Black BER7321B1

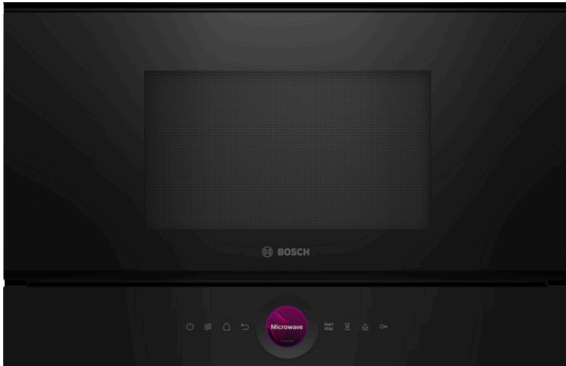

Included accessories

1 x grid
1 x Glass tray

The compact microwave 38cm. Inverter Technology: constant microwave power for heating food gradually. Microwave Boost Function: quick and easy warming.

- **Digital Control Ring:** the simple and innovative way to select oven settings.
- **TFT Touch Display:** easy control thanks to an innovative Digital Control Ring and TFT touchscreen.
- **Auto Pilot 10:** every dish is a perfect success thanks to 10 pre-set automatic programmes.
- **Stainless steel interior:** easy to clean interior thanks to smooth surfaces and no sharp edges.
- **Cleaning Assistance:** less cleaning effort

Technical Data

Type of micro-wave oven : MW+Grill function

Type of control : Electronic

Dimensions : 382 x 594 x 318 mm

Cavity dimensions : 230 x 350 x 270 mm

Length electrical supply cord : 175.0 cm

Net weight : 18.4 kg

Gross weight : 20.4 kg

EAN code : 4242005319565

Maximum micro-wave power : 900 W

Connection Rating : 1990 W

Fuse protection : 10 A

Voltage : 220-240 V

Frequency : 50; 60 Hz

Plug type : GARDY plug w/ earthing

Cavity dimensions : 230 x 350 x 270 mm

Included accessories : 1 x grid, 1 x Glass tray



4 242005 319565

Series 8, Built-In Microwave, Black BER7321B1

**The compact microwave 38cm. Inverter
Technology: constant microwave power for
heating food gradually. Microwave Boost
Function: quick and easy warming.**

Dimensions:

- Appliance dimension (HxWxD): 382 mm x 594 mm x 318 mm
- Niche dimension (HxWxD): 362 mm - 382 mm x 560 mm - 568 mm x 300 mm
- "Please reference the built-in dimensions provided in the installation drawing"

Microwave and heating mode:

- Max. Power: 900 W; 5 Microwave power settings: 90 W, 180 W, 360 W, 600 W, boost
- Intelligent inverter technology: maximum output power will be regulated to 600 W when used in longer operation
- Grill 1.3 KW
- Grill and microwave power levels 90 W, 180 W, 360 W combinable

Design:

- stainless steel cavity with glass bottom
- Touch control
- Touch key operation

Cleaning:

- Catalytic ceiling
- Cleaning Assistance (program)

Comfort:

- electronic clock
- TFT-touchdisplay, Electronic Control
- User-friendly electronics: extremely easy and comfortable operation
- AutoPilot 10
- Quick Start: one tap to maximum microwave power for 30 seconds
- LED light
- Cavity volume: 21 l
- side opening door, hinge right

Accessory:

- 1 x grid, 1 x Glass tray

Environment and Safety:

- Start-/Stop button
Door contact switch
- Integral cooling fan

Technical Information

- Length of mains cable: 175 cm
- Total connected load electric: 1.99 KW
- Nominal voltage: 220 - 240 V
- suitable for high cupboard installation, can be built in a 60 cm wall cupboard (at least 30 cm deep)

Series 8, Built-In Microwave, Black BER7321B1

measurements in mm

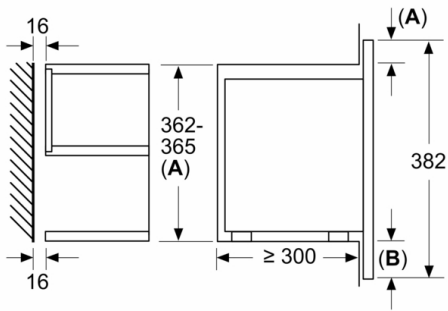

- A:** Overhang at top:
 Recess 362: 6 mm
 Recess 365: 3 mm
B: Overhang at bottom: 14 mm

Measurements in mm

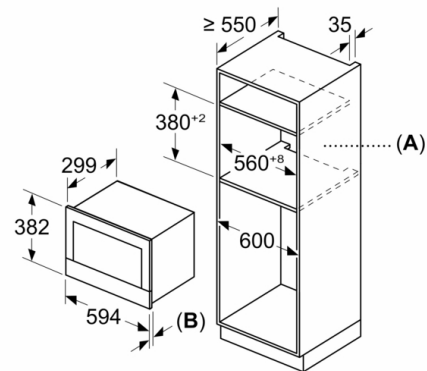

- A:** Back wall open
B: 19.5 mm

Measurements in mm

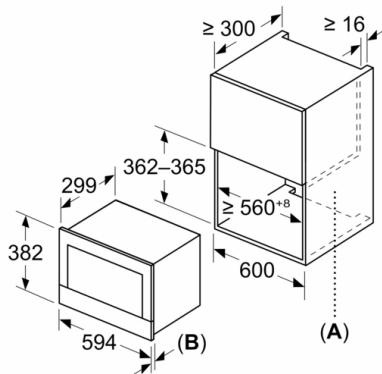

- A:** Back wall open
B: 19.5 mm