

**Series 2, built-in fridge-freezer with freezer at bottom, 193.5 x 54.1 cm, sliding hinge
KIN96NSE0**



KSZB6R00 Bottle Rack
KSZGGM00 Butter box

- **NoFrost:** never defrost again, thanks to perfect protection from ice formation - that saves time and effort.
- **LED Lighting:** keep your groceries in perfect view.
- **2 Cooling Systems:** separately controllable refrigerator and freezer compartments
- **Super Cooling function:** cools new food placed inside faster, thus protecting already cooled food.

Energy Efficiency Class (Regulation (EU) 2017/1369): E
 Average annual energy consumption in kilowatt hour per year (kWh/a) (EU) 2017/1369:231 kWh/annum
 Sum of volume of frozen compartments (EU 2017/1369): 75 l
 Sum of volume of chill- and unfrozen compartments (EU 2017/1369): 215 l
 Airborne acoustical noise emissions (EU 2017/1369): ..34 dB(A) re 1 pW
 Airborne acoustical noise emission class (EU 2017/1369): B
 Built-in / Free-standing: Built-in
 Number of compressors: 1
 Number of independent cooling systems:2
 Width of the appliance: 541 mm
 Height: 1935 mm
 Depth of the product: 548 mm
 Net weight: 54.9 kg
 Min. required niche size for installation (HxWxD): ..1940 x 560 x 550 mm
 Door panel options: Not possible
 Door hinge: Right reversible
 Number of Adjustable Shelves in fridge compartment: 4
 Shelves for Bottles: No
 Frost free system: Fridge
 Interior ventilator: No
 Reversible Door Hinge: Yes
 Length electrical supply cord: 230.0 cm
 Multi-Flow Air Tower: No
 Fast cooling switch:Yes
 Fast freezing switch:Yes
 Temperature Controlled Drawer:No
 Humidity Control Drawer:No
 Number of Door Bins - Refrigerator:4
 Door bin adjustability - Refrigerator: Yes
 Tilt-out door bins in fridge:Yes
 Gallon wide door bins: Yes
 Number of Gallon storage: 1
 Motorized Shelf: No
 Material of the shelves: Safety glass
 Door opened indicator freezer:No
 Automatic motor-driven ice-maker: No
 Fuse protection: 10 A
 Voltage: 220-240 V
 Frequency: 50 Hz
 Storage Period in Event of Power Failure (h): 10 h
 Door panel options: Not possible
 Energy Star Qualified:No
 Plug type: GARDY plug w/ earthing
 Required cutout/niche size for installation (in):x
 Dimensions of the packed product: 79.52 x 24.40 x 24.80
 Net weight: 121.000 lbs
 Gross weight: 134.000 lbs



Series 2, built-in fridge-freezer with freezer at bottom, 193.5 x 54.1 cm, sliding hinge KIN96NSE0

Performance and consumption

- EU19_EEK_D: E
- Total Volume : 290 l
- Annual Energy Consumption: 231 kWh/a
- Noise Level : 34 dB

Design and Styling

- LED interior light in fridge section
- Built-in-refrigerator 2-door, Bottom Fre

Convenience & Safety

- NoFrost - never again defrosting!
- yes
- Separate, electronic temperature control, LED indicators
- Two Cooling Systems
- Super Cooling: automatic deactivation
- Optical and acoustic door open warning system
- Automatic defrost in fridge section

Fridge Compartment

- Net Fridge Volume : 215 l
- 5 safety glass shelves, of which 4 are height adjustable
- 1 door shelf large, 3 door shelf small

Freshness System

Freezer Section

- Net Freezer Volume : 75 l
- Freezing capacity 24h : 7.5 kg
- Temperature rise time : 10 H
- 3 transparent freezer drawers

Dimensions

- Dimensions (H x W x D): 193.5 cm x 54.1 cm x 54.8 cm
- Niche Dimension (H x W x D): 194.0 cm x 56.0 cm x 55.0 cm

Technical Information

- Door right hinged, reversible
- Height adjustable front feet
- Climate Class: SN-ST
- Nominal voltage: 220 - 240 V

Accessories

- egg tray
- ice cube tray

Country Specific Options

- Based on the results of the standard 24-hour test. Actual consumption depends on usage/position of the appliance.

Environment and Safety

Installation

General Information

- Without Illumination

**Series 2, built-in fridge-freezer with
freezer at bottom, 193.5 x 54.1 cm,
sliding hinge
KIN96NSE0**

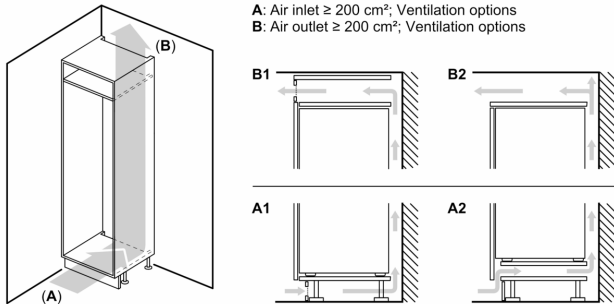

Measurements in mm

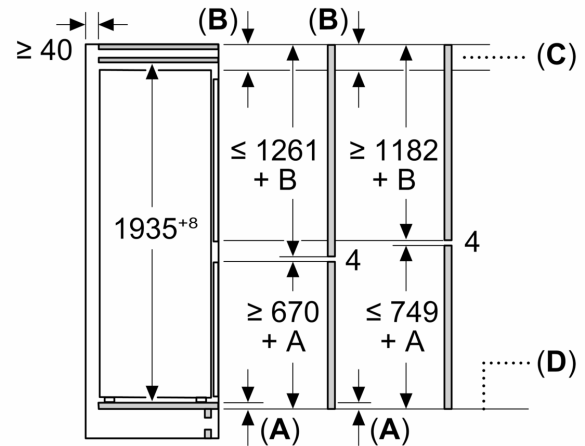

C: Front panel overhang

D: Lower edge of front panel

Measurements in mm

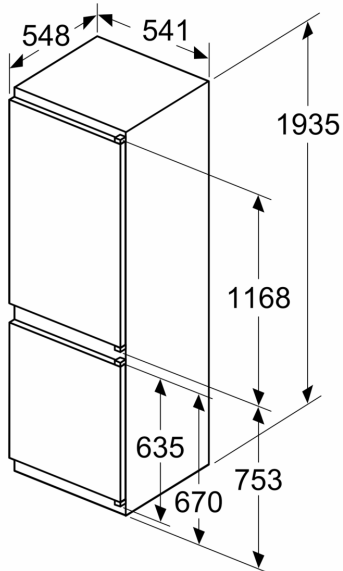

Measurements in mm

