

**Series 2, fully-integrated dishwasher,
60 cm
SMV2ITX48E**



**Connected dishwasher with noise reduction
at any time via the Home Connect App.**

- **ExtraDry:** selectable option for additional drying.
- **Height Adjustable Top Basket:** offers extra space, especially for tall dishes.
- **Silence on demand:** up to 30 min noise reduction at any time via the Home Connect App.
- **Home Connect:** home appliances with smart connectivity for an easier everyday life.
- **Info Light:** a red light on the floor indicates whether the dishwasher is switched on or off.

Technical Data

Energy Efficiency Class (Regulation (EU) 2017/1369): E
 Energy Consumption for 100 cycles Eco Programme: 92 kWh
 Maximum number of place settings: 12
 The water consumption of the eco programme in liters per cycle: 9.5 l
 Programme duration: 4:10 h
 Airborne acoustical noise emissions : 46 dB(A) re 1 pW
 Airborne acoustical noise emission class: C
 Built-in / Free-standing: Built-in
 Height of removable worktop: 0 mm
 Dimensions of the product (HxWxD): 815 x 598 x 550 mm
 Min. required niche size for installation (HxWxD): 815-875 x 600 x 550 mm
 Depth with open door 90 degree: 1150 mm
 Adjustable feet: Yes - all from front
 Maximum adjustability feet: 60 mm
 Net weight: 34.7 kg
 Gross weight: 36.8 kg
 Connection Rating: 2400 W
 Fuse protection: 10 A
 Voltage: 220-240 V
 Frequency: 50; 60 Hz
 Repair index: 8.8
 Length electrical supply cord: 175.0 cm
 Plug type: Gardy plug w/ earthing
 Length inlet hose: 165 cm
 Length outlet hose: 190 cm
 EAN code: 4242005176489
 Installation typology: Full-integrated

Optional accessories

SMZ2014 : Rack insert for stemware dishwasher
 SMZ5300 : GlassSecure Tray



Series 2, fully-integrated dishwasher, 60 cm SMV2ITX48E

Connected dishwasher with noise reduction at any time via the Home Connect App.

- Energy Efficiency Class¹: E
- Energy² / Water³: 92 kWh / 9.5 litres
- Capacity: 12 place settings
- Programme duration⁴: 4:10 (h:min)
- Noise level: 46 dB(A) re 1 pW
- Noise Efficiency Class: C

BOSCH - Header 1

- Home Connect enabled via WLAN

BOSCH - Header 2

- 5 programmes: Eco 50 °C, Auto 45-65 °C, Intensive 70 °C, Express 65 °C, Favourite (Pre-Rinse)
- Favourite function
- 3 special options: Remote Start, Extra Dry, Half Load
- Machine Care Programme
- Silence on Demand (Quiet now) (via app)

BOSCH - Header 3

- AquaSensor
- DosageAssist
- EcoSilence Drive
- Detergent Automation
- Self-cleaning filter system with 3-fold corrugated filter
- Interior tub material: Stainless Steel/Polinox

BOSCH - Header 4

- Vario basket system
- Low friction wheels on bottom basket
- Rack Stopper to prevent derailing of bottom basket
- Height adjustable top basket
- 2 foldable plate racks in bottom basket
- No
- Cutlery basket in bottom basket

BOSCH - Header 5

- Controls on top edge of door
- Panel legend: Plain text (english)
- Info Light (red)
- Electronic delay timer: 3, 6 or 9 hours

BOSCH - Header 6

- AquaStop: Bosch warranty in case of water damage – for the lifetime of the appliance.*
- Glass protection technology
- incl. Steam protection plate

BOSCH - Header 7

- Product dimensions (HxWxD): 81.5 x 59.8 x 55 cm

BOSCH - Header 8

- ¹ Scale of Energy Efficiency Classes from A to G
- ² Energy consumption in kWh per 100 cycles (in programme Eco 50 °C)
- ³ Water consumption in litres per cycle (in programme Eco 50 °C)
- ⁴ Duration of programme Eco 50 °C
- * Please find warranty terms under [please insert here the local URL (internet address, e.g. <https://www.bosch-home.com/> but with the direct page with the warranty terms)

Series 2, fully-integrated dishwasher, 60 cm SMV2ITX48E

measurements in mm



⌚ socket
() values with extension kit

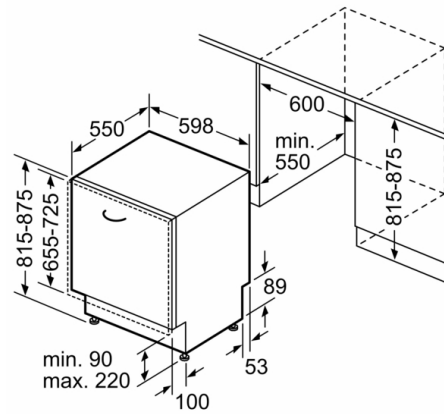

measurements in mm