

Series 6, Integrated Design Hood, 90 cm, clear glass black printed DBB97AM60



B

DWZ0IT0P0	Long Life odor filter (replacement)
DWZ1IB6K1	Chimney extension 450-854 mm
DWZ1IB6N1	Chimney extension 187-360 mm
DWZ1IT1D1	Long Life recirculation kit external
DWZ1IX1B6	Clean Air Plus odor filter (replacement)
DWZ1IX1C6	Clean Air Plus recirc. kit external
DWZ6IB1B4	Clean Air Standard odor filter (repl.)
DWZ6IB1I4	Clean Air Standard recirculation kit

Perfectly integrated design hood for optimal usage of space inside your cupboard.

- **Silent:** maximal extractor performance with little noise
- **Expanded storage space:** enjoy fresh air and extra storage with our space-saving hood.
- **Glass panel with integrated Touch Select Control:** easy access controls for hassle-free kitchen experience.
- **Easy to clean:** enjoy effortless cleaning with our sleek, user-friendly ventilation hood.

Typology: Built-in/Built-under
 Length electrical supply cord: 130.0 cm
 Min. required niche size for installation (HxWxD): 340mm x 860.0mm x 300mm mm
 Height of product, without chimney: 60 mm
 Net weight: 14.0 kg
 Type of control: Electronic
 Number of speed settings: 3-stages + intensive setting
 Max. air extraction: 460 m³/h
 Boost position output recirculating: 652 m³/h
 Max. air recirculation: 451 m³/h
 Boost position air extraction: 749 m³/h
 Number of lights: 3
 Noise level: 63 dB(A) re 1 pW
 Diameter of air outlet: 150 / 120 mm
 Grease filter material: Washable stainless steel
 Odour filter: No
 Operating Mode: Exhaust / Recirculation (Accessory available separately)
 Optional accessories: DWZ0IT0P0, DWZ1IB6K1, DWZ1IB6N1, DWZ1IT1D1, DWZ1IX1B6, DWZ1IX1C6, DWZ6IB1B4, DWZ6IB1I4
 Total power of the lamps: 9 W
 Grease filter type: Kassette
 Connection rating: 259 W
 Voltage: 220-240 V
 Frequency: 50 Hz
 Plug type: Gardy plug w/ earthing
 Installation typology: Built-in
 Material body: Lacquered
 Plug type: Gardy plug w/ earthing
 Dimensions of the product, with chimney (if exists) (in): x x
 Dimensions of the packed product: 23.03 x 25.59 x 38.18
 Net weight: 31.000 lbs
 Gross weight: 45.000 lbs
 Motor location: Integrated motor in hood body
 No-return airflow flap: Yes
 Length electrical supply cord: 130.0 cm
 Dimensions of the product, with chimney (if exists): .x 897.0 x 298.0 mm
 Dimensions of the packed product (HxWxD): 585 x 650 x 970 mm
 Net weight: 14.0 kg
 Gross weight: 20.6 kg



4 242005 278206

Series 6, Integrated Design Hood, 90 cm, clear glass black printed DBB97AM60

Perfectly integrated design hood for optimal usage of space inside your cupboard.

Variant

- 90 cm wide
- For installation in a special wall cupboard (90 cm)
- Suitable for ducted or re-circulated extraction
- For recirculated extraction various recirculation kits are available as optional accessories.

Design

- Flush-fitted installation for a seamless integration in wall cupboards.
- Space efficient, compact design for extra storage possibilities on the hood and up to max. 10 kg storage weight per side.
- Glass panel with touch control for an easy operation and enhanced vapor capture.

Comfort

- Electronic controls via TouchControl with Electronic display
- 3 speeds plus intensive setting
- Automatic revert
- Automatic revert setting, 6 minutes
- The fan and light are automatically turned on and off by opening and closing the glass panel.
- The light can also be independently turned on and off when the glass panel is closed by quick hand touch on control area.

Features

- 3 x 2 W LED
- SoftLight
- Colour Temperature: 3500 K
- Light Intensity: 517 lux
- Energy efficient capacitor motor
- Metal grease filter, dishwasher safe
- cassette w. stainl.steel frame
- Easy to clean smooth surfaces and materials.

Performance

- Extraction rate according to EN 61591 ø 15 cm:
 - max. Normal use: 460 m³/h
 - Intensive: 749 m³/h
- Noise level according to EN 60704-2-13 exhaust air:
 - Max. normal use: 63 dB(A) re 1 pW
 - Intensive: 73 dB(A) re 1 pW
 - Noise min./max. Normal Level: 50/63 dB
- With the Clean Air Plus recirculation kit (available as optional accessory) your appliances reaches:
 - Extraction rate in recirculation mode: Max. normal use: 451 m³/h
 - Intensive: 652 m³/h
 - Noise level in recirculation mode: Max. normal use: 67 dB(A) re 1 pW
 - Intensive: 74 dB(A) re 1 pW

Planning and installation information

- Suitable for installation in bottomless wall cupboards
- Enclosed spacers for installation in wall cupboards with maximum depth of up to 360 mm.
- Enclosed mats for protection against scratches and dirt of storage space on hood sides.
- For installation in higher wall cupboards decorative chimney extensions are available as optional accessories.
- Chimney extensions are compatible with the available recirculation kits.
- Dimensions (HxWxD): 340 x 897 x 298 mm
- Built-in dimensions (HxWxD): 340 x 860 x 300 mm
- Diameter pipe ø 150 mm (ø 120 mm enclosed)
- with one-way flap
- Electrical cable length 1.3 m
- Please reference the built-in dimensions provided in the installation drawing

Consumption Data

- Energy Efficiency Class: B (at a range of energy efficiency classes from A+++ to D)
- Average Energy Consumption: 64.7 kWh/year
- Blower Efficiency Class: B*
- Lighting Efficiency Class: A
- Grease Filtering Efficiency Class: B
- Power rating: 259 W

* In accordance with the EU-Regulation No 65/2014

**Series 6, Integrated Design Hood, 90 cm, clear glass black printed
DBB97AM60**

measurements in mm
Front view

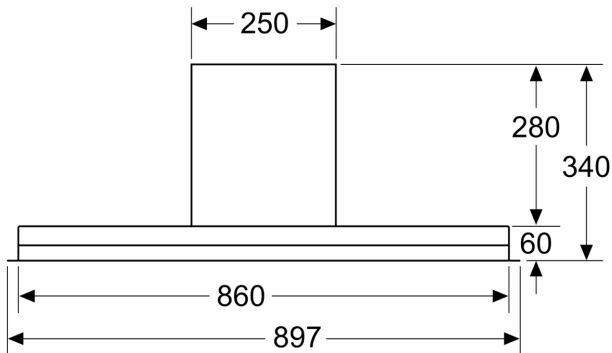

measurements in mm
Installation example

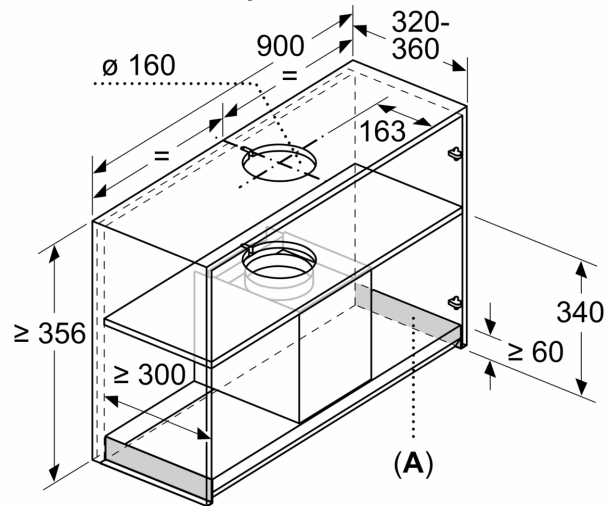

A: Area without hinges

measurements in mm

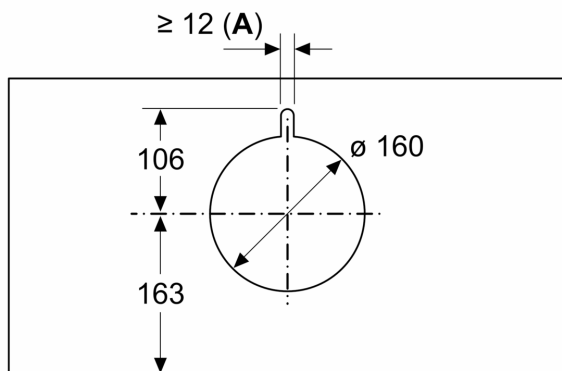

A: Cable bushing

measurements in mm

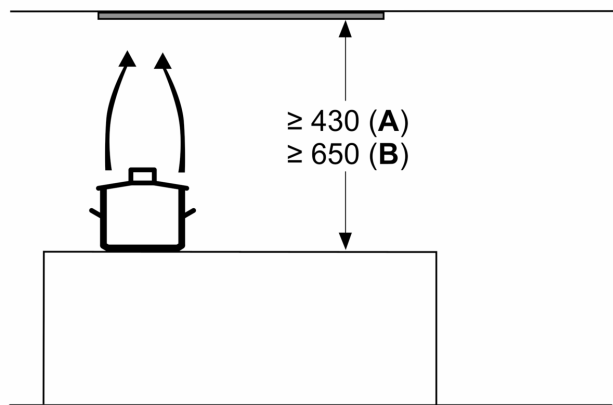

from upper edge of pan support
A: min. 430 electric
B: min. 650 gas

measurements in mm
side view

