

**Series 8, fully-integrated dishwasher,
60 cm
SMV8YCX02E**



**Energy label A dishwasher, thanks to our
Smart Energy Saving Solutions with no
constraining compromises to perfect
results.**

- **PerfectDry:** perfect drying results with low energy consumption even with hard-to-dry items.
- **Intelligent Programme:** Individually adapts the washing and drying cycle based on your feedback.
- **Max Flex Pro baskets:** easy loading with protection for your dishes.
- **Silence Plus:** the remarkably quiet 44 dB dishwasher.
- **Home Connect:** home appliances with smart connectivity for an easier everyday life

- SGZ0BI01 decorative strips stainless steel 81,5cm
- SGZ0IC00 Small Item Clip for upper rack
- SGZ1010 inlet and outlet hose extention
- SGZ8BI00 Connection rail for divided furniture
- SMZ1051EU Mains cable with EU-Plug 5m
- SMZ2014 Rack insert for stemware dishwasher
- SMZ2056 Attachment door, stainless steel
- SMZ5000 Dishwashing aid set
- SMZ5003 Retractable hinge f. high corpus dimens.
- SMZ5035 Decor conversion kit, stainless steel
- SMZ5100 Vario-cutlery basket
- SMZ5300 GlassSecure Tray

Energy Efficiency Class (Regulation (EU) 2017/1369): A
 Energy Consumption for 100 cycles Eco Programme: 54 kWh
 Maximum number of place settings: 14
 The water consumption of the eco programme in liters per cycle: 9.5 l
 Programme duration: 4:55 h
 Airborne acoustical noise emissions :44 dB(A) re 1pW
 Airborne acoustical noise emission class:B
 Cleaning performance:A
 Water consumption:9.5 l
 Total annual water consumption 220 days:2090 l
 Built-in / Free-standing: Built-in
 Removable top: No
 Door panel options: Not possible
 Height of removable worktop: 0 mm
 Height of the appliance: 815 mm
 Adjustable feet: Yes - all from front
 Maximum adjustability feet: 60 mm
 Adjustable plinth: Both horizontal and vertical
 Net weight:43.1 kg
 Gross weight: 45.0 kg
 Connection rating: 2400 W
 Fuse protection:10 A
 Voltage: 220-240 V
 Frequency: 50; 60 Hz
 Length electrical supply cord: 175.0 cm
 Plug type: Gardy plug w/ earthing
 Length inlet hose: 165 cm
 Length outlet hose: 190 cm
 Hidden heating element: Yes
 Water protection system description: Triple water protection 24h
 Child safety devices: No
 Water softener:Yes
 Top basket type: Maximum flexibility with Max Flex Pro basket
 Adjustable upper basket:Rackmatic 3-stage
 Bottom basket type: R4
 3rd Rack:VarioDrawer Pro
 Optional accessories:SGZ0BI01, SGZ0IC00, SGZ1010, SGZ8BI00, SMZ1051EU, SMZ2014, SMZ2056, SMZ5000, SMZ5003, SMZ5035, SMZ5100, SMZ5300
 Included accessories 2: Vapor barrier plate
 Number of place settings: 14
 Dimensions of the product (HxWxD):815 x 598 x 550 mm
 Dimensions of the packed product (HxWxD): 880 x 660 x 670 mm



Series 8, fully-integrated dishwasher, 60 cm SMV8YCX02E

Energy label A dishwasher, thanks to our Smart Energy Saving Solutions with no constraining compromises to perfect results.

BOSCH - Header 1

- Energy Efficiency Class¹: A
- Energy² / Water³: 54 kWh / 9.5 litres
- Capacity: 14 place settings
- Programme duration⁴: 4:55 (h:min)
- Noise level: 44 dB(A) re 1 pW
- Noise Efficiency Class: B
- Noise level (Silence 50°C programme): 43 dB(A) re 1 pW

BOSCH - Header 2

- 8 Programmes: Eco 50 °C, Auto 45-65 °C, Intelligent, Intensive 70 °C, Express 60 °C, Glass 40 °C, Silence 50 °C, Favourite (Pre-Rinse)
- Favourite function
- 5 special options: Remote Start, Extra Dry, Intensive Zone, Hygiene+, SpeedPerfect+
- Machine Care Programme
- Add-On functions via Home Connect app: Half Load, Silence on Demand (Quiet now)

BOSCH - Header 3

- Zeolith-Drying
- EfficientDry and Heat exchanger
- AquaSensor
- DosageAssist
- EcoSilence Drive
- Detergent Automation
- Self-cleaning filter system with 3-fold corrugated filter
- Interior tub material: Stainless Steel

BOSCH - Header 4

- Max Flex Pro Baskets with red coloured touchpoints
- Extra Clean Zone
- VarioDrawer Pro
- Rackmatic height-adjustable top basket (3 stage)
- Easy Slide pullout system on top basket
- Low friction wheels on bottom basket
- Coloured anti-slip protection strips in top basket
- Rack Stopper to prevent derailing of bottom basket
- 6 foldable plate racks in top basket
- 8 FlexTines in bottom basket
- 2 cup shelves with soft silicone front part in top basket
- 2 cup shelves in bottom basket
- Anti-slip protection strip for wine glasses in top basket
- Glass rack in bottom basket

BOSCH - Header 5

- Home Connect enabled via WLAN

- High-definition colour TFT display showing graphic symbols and plain text
- Touch Control (metallic)
- Controls on top edge of door
- Panel legend: Plain text (english)
- EmotionLight
- Time Light
- Real-time clock
- Acoustic end of cycle indicator
- Electronic delay timer: 1-24 hours

BOSCH - Header 6

- AquaStop: Bosch warranty in case of water damage – for the lifetime of the appliance.*
- Precise glass protection technology

BOSCH - Header 7

- incl. Salt filling funnel
- incl. Steam protection for worktop

BOSCH - Header 8

- Product dimensions (HxWxD): 81.5 x 59.8 x 55 cm

¹ Scale of Energy Efficiency Classes from A to G

² Energy consumption in kWh per 100 cycles (in programme Eco 50 °C)

³ Water consumption in litres per cycle (in programme Eco 50 °C)

⁴ Duration of programme Eco 50 °C

* Please find warranty terms under [please insert here the local URL (internet address, e.g. <https://www.bosch-home.com/> but with the direct page with the warranty terms)

**Series 8, fully-integrated dishwasher,
60 cm
SMV8YCX02E**

measurements in mm

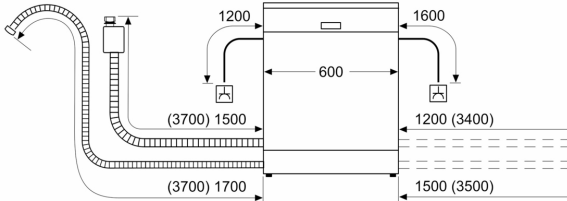

⌚ socket
() values with extension kit

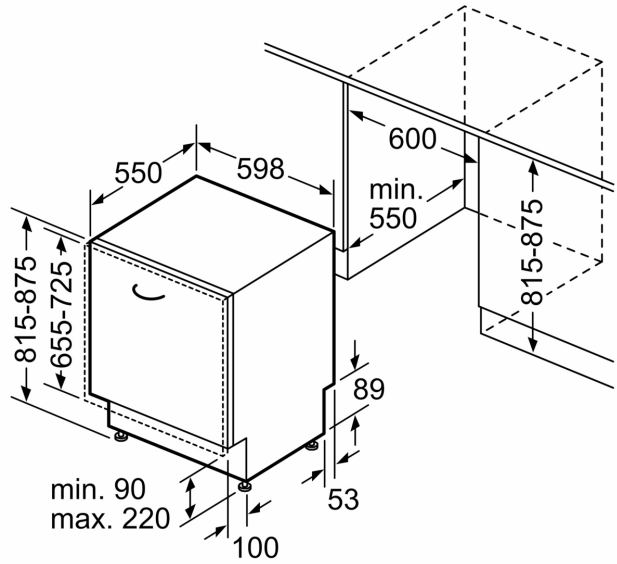

measurements in mm