

N 50, BUILT-IN FRIDGE-FREEZER WITH FREEZER AT BOTTOM, 177.2 X 54.1 CM, SLIDING HINGE K15862SE0S



GS6B0BZ0	Box-in-Freezer-Box
KS6B0RZ0	Bottle Rack
KS9E0FZ0	Package Neff FlexCooling
KSGG0MZ0	Butter box

This built-in fridge-freezer with Fresh Safe 1 keeps fruits and vegs fresh, ensures ideal air circulation in the fridge.

- ✓ Eco Air Flow – Even air circulation for constant temperatures and fast cooling.
- ✓ Low Frost – Reduces frost in the freezer compartment for faster defrosting
- ✓ Big Box: Large pieces of frozen delicacies fit easily into this roomy drawer in your freezer
- ✓ LED Light – Pleasantly bright light in the entire fridge with long-life LEDs.
- ✓ Adjustable Glass Shelves – Height adjustable shelves create the space you need for inspiring dishes in your fridge

Energy Efficiency Class (Regulation (EU) 2017/1369):	E
Average annual energy consumption in kilowatt hour per year (kWh/a):	229 kWh/annum
Sum of volume of frozen compartments:	84 l
Sum of volume of chill compartments:	183 l
Airborne acoustical noise emissions :	35 dB(A) re 1pW
Airborne acoustical noise emission class:	B
Design:	Built-in
Number of compressors:	1
Number of independent cooling systems:	1
Width of the appliance:	541 mm
Height:	1772 mm
Depth of the product:	548 mm
Net weight:	50.7 kg
Required niche size for installation (HxWxD):	.. 1775.0 x 560 x 550 mm
Door panel options:	Not possible
Door hinge:	Right reversible
Number of Adjustable Shelves in fridge compartment:	3
Shelves for Bottles:	No
Frost free system:	No
Interior ventilator:	No
Reversible Door Hinge:	Yes
Length electrical supply cord:	230.0 cm
Noise level:	35 dB(A) re 1pW
Multi-Flow Air Tower:	No
Fast cooling switch:	No
Fast freezing function:	Yes
Temperature Controlled Drawer:	No
Humidity Control Drawer:	No
Number of Door Bins - Refrigerator:	3
Door bin adjustability - Refrigerator:	Yes
Tilt-out door bins in fridge:	Yes
Gallon wide door bins:	Yes
Number of Gallon storage:	1
Motorized Shelf:	No
Material of the shelves:	Safety glass
Door opened indicator freezer:	No
Automatic motor-driven ice-maker:	No
Fuse protection:	10 A
Voltage:	220-240 V
Frequency:	50 Hz
Storage Period in Event of Power Failure (h):	9 h
Door panel options:	Not possible
Noise level:	35 dB(A) re 1pW

ENERGY STAR® certified: No
Plug type: Gady plug w/ earthing
Required cutout/niche size for installation (in): x
Dimensions of the packed product: 72.45 x 24.01 x 25.19
Net weight: 112.000 lbs
Gross weight: 122.000 lbs



*N 50, BUILT-IN FRIDGE-FREEZER WITH FREEZER
AT BOTTOM, 177.2 X 54.1 CM, SLIDING HINGE
KI5862SE0S*

- easy Installation

Performance and consumption

Design and Styling

- LED interior light in fridge section

Convenience & Safety

- LED electronic control
- Super Cooling: No
- Super Freezing: manual activation
- Acoustic open door warning system

Fridge Compartment

- 4 safety glass shelves, thereof 3 height adjustable, Bottle Flex Shelf, Standard
- 1 door bin(s) high
- 3 door bins, thereof 1 door bin(s) high
- BottleFlex Shelf - flexible storage of all kind of food and drinks

Freshness System

- 1 FreshSafe drawer with humidity control retains freshness for longer.

Freezer

- Low Frost
- 3 transparent freezer drawers, incl.1 big box

Dimensions

- Appliance Dimensions (H x W x D): 177.2 cm x 54.1 cm x 54.8 cm
- Niche Dimension (H x W x D): 177.5 cm x 56.0 cm x 55.0 cm

Technical Information

- Door right hinged, reversible
- Nominal voltage: 220 - 240 V

Accessories

- ice cube tray
- ice cube tray

Country Specific Options

- Based on the results of the standard 24-hour test. Actual consumption depends on usage/position of the appliance.

Environment and Safety

Installation

General Information

- Energy Class: E
- Total Volume: 267 l
- Net Fridge Volume : 183 l
- Net Freezer Volume : 84 l
- Net 4* compartment volume : 84 l
- Freezing capacity 24h: 4.2 kg
- Annual Energy Consumption: 229 kWh/a
- Climate Class: SN-ST
- Fast Freeze Facility

- Noise Level : 35 dB , B Class
- Temperature rise time : 9 H
- Sliding hinge, Soft closing: no
- Type of hinge: Follow-door

N 50, BUILT-IN FRIDGE-FREEZER WITH FREEZER
AT BOTTOM, 177.2 X 54.1 CM, SLIDING HINGE
KI5862SE0S

measurements in mm

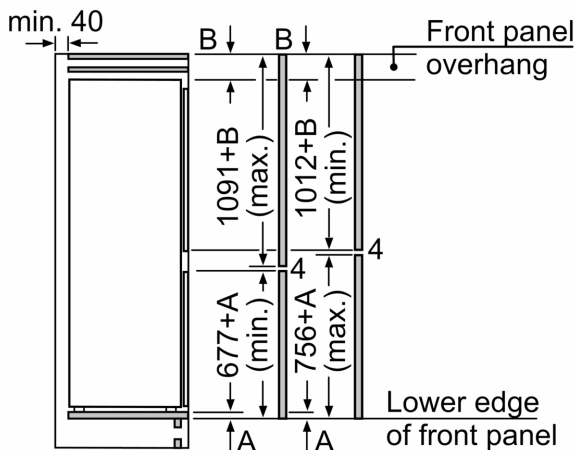
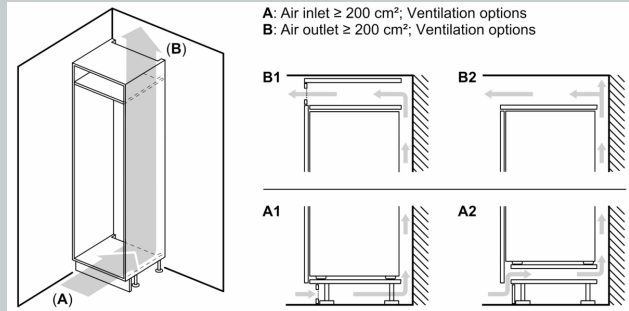
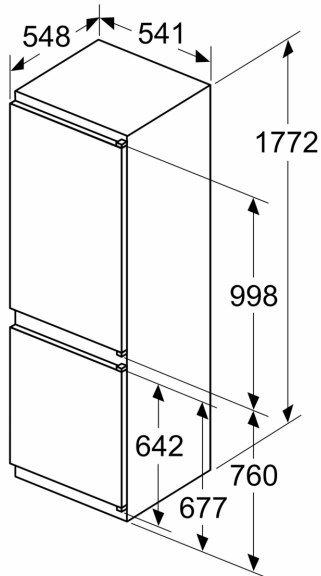

The specified unit door dimensions
are valid for a door gap of 4 mm.
measurements in mm

