

Series 4, Built-In Microwave, Black BFL523MB1F



Included accessories

1 x Turntable

Optional accessories

HEZ86D000 : Steamer Cooker Accessory for Microwave

The built-in microwave for the 38 cm niche: use it for extra fast thawing, heating and perfect preparation of foods.

- **AutoPilot 7:** every dish is a perfect success thanks to 7 pre-set automatic programmes.
- **LED-display control, red:** easy-to-use thanks to the time functions.
- **Pop-out controls:** Make the front of the oven easy to clean and give it a sleek look.
- **Stainless steel interior:** easy to clean interior thanks to smooth surfaces and no sharp edges.
- **Cleaning Assistance:** less cleaning effort thanks to the new cleaning option, which can be especially used for cleaning of light soiling.

Technical Data

Type of control : Electronic

Dimensions : 382x594x317 mm

Cavity dimensions : 201 x 308 x 282 mm

Length electrical supply cord : 130.0 cm

Net weight : 16.1 kg

Gross weight : 20.8 kg

Maximum micro-wave power : 800 W

Number of Power Levels : 5

Turntable : Yes

Cavity material : Stainless steel

Door opening : Button

Clock : Yes

Included accessories : 1 x Turntable

Height of the appliance : 382 mm

Width of the appliance : 594 mm

Depth of the product : 317 mm

Maximum micro-wave power : 800 W

Connection Rating : 1270 W

Fuse protection : 10 A

Voltage : 230-240 V

Frequency : 50 Hz

Plug type : GARDY plug w/ earthing

Required cutout/niche size for installation (in) : x

Dimensions of the packed product : 18.50 x 16.92 x 27.16

Net weight : 35.000 lbs

Gross weight : 46.000 lbs



4 242005 476541

Series 4, Built-In Microwave, Black BFL523MB1F

**The built-in microwave for the 38 cm niche:
use it for extra fast thawing, heating and
perfect preparation of foods.**

Dimensions:

- Appliance dimension (HxWxD): 382 mm x 594 mm x 317 mm
- Niche dimension (HxWxD): 362 mm - 365 mm x 560 mm - 568 mm x 300 mm
- "Please reference the built-in dimensions provided in the installation drawing"

Microwave and heating mode:

- Max. Power: 800 W; 5 Microwave power settings: 90 W, 180 W, 360 W, 600 W, 800 W
- Cavity volume: 20 l

Design:

- stainless steel cavity

Cleaning:

- Cleaning Assistance (manually)

Comfort:

- LED display control
- electronic clock
- Rotary Control, Pop-out controls, Touch control
- User-friendly electronics: extremely easy and comfortable operation
- AutoPilot 7
- 4 defrost and 3 cooking programmes in microwave function
- Memory for individual programmes (1 setting)
- LED light
- 25.5 cm glass turntable
- side opening door, hinge left
- Electronic door opener
- Touch key operation

Accessory:

- 1 x Turntable

Environment and Safety:

- Door contact switch
- Integral cooling fan

Technical Information

- Length of mains cable: 130 cm
- Total connected load electric: 1.27 KW
- Nominal voltage: 230 - 240 V
- suitable for high cupboard installation, can be built in a 60 cm wall cupboard (at least 30 cm deep)

Series 4, Built-In Microwave, Black BFL523MB1F

Measurements in mm

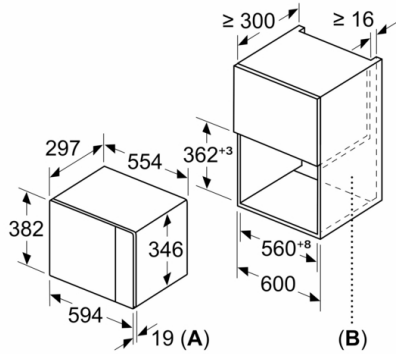

A: 20 mm for metal fascia
B: Back panel open

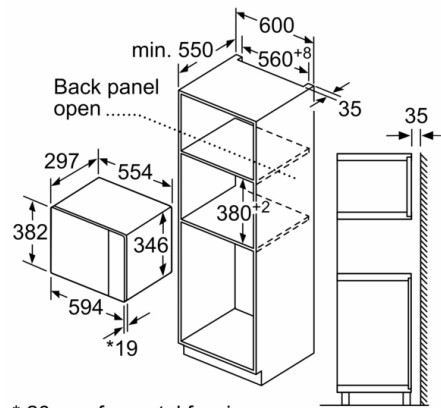

* 20 mm for metal fascia

measurements in mm

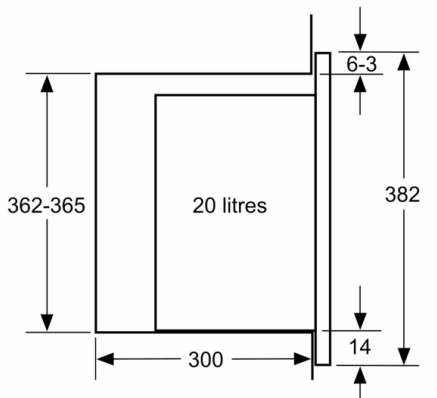

measurements in mm

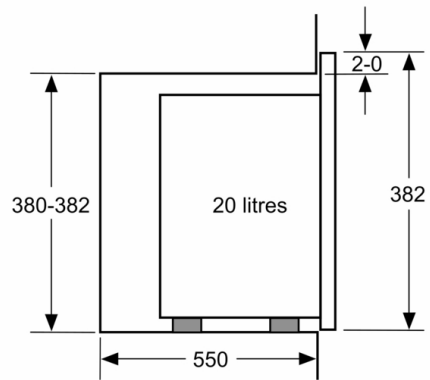

measurements in mm

Microwave,
corner installation

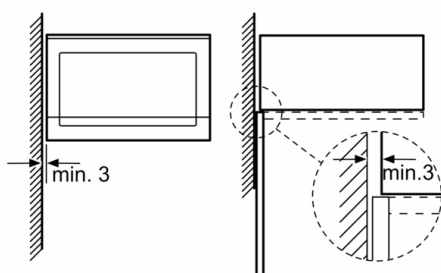

Measurements in mm