

Series 2, built-in fridge-freezer with freezer at bottom, 177.2 x 54.1 cm, sliding hinge KIV86NSE0



The spacious built-in fridge-freezer combination with LowFrost provides optimal food storage and ice formation is significantly reduced.

- **Multi Box XXL:** extra-large drawer for your fruit and vegetables.
- **Eco Airflow:** optimal air circulation and even temperature level in the cooling area.
- **Low Frost:** defrost less often thanks to lower ice formation - saves work and is energy-efficient.
- **Door Open Alarm:** Reminds you if the door is not closed properly.
- **Made in Germany:** high quality standards and thorough testing for enduring satisfaction.



- GSZB6B00 Box-in-Freezer-Box
- KSZB6R00 Bottle Rack
- KSZGGM00 Butter box

Energy Efficiency Class (Regulation (EU) 2017/1369): E
Average annual energy consumption in kilowatt hour per year (kWh/a): 229 kWh/annum
Sum of volume of frozen compartments: 84 l
Sum of volume of chill compartments: 183 l
Airborne acoustical noise emissions :35 dB(A) re 1pW
Airborne acoustical noise emission class:B
Built-in / Free-standing: Built-in
Number of compressors: 1
Number of independent cooling systems: 1
Width of the appliance:541 mm
Height: 1772 mm
Depth of the product: 548 mm
Net weight:51.2 kg
Required niche size for installation (HxWxD):	... 1775 x 560 x 550 mm
Door panel options: Not possible
Door hinge: Right reversible
Number of Adjustable Shelves in fridge compartment: 3
Shelves for Bottles: No
Frost free system:No
Interior ventilator: No
Reversible Door Hinge:Yes
Length electrical supply cord: 230.0 cm
Multi-Flow Air Tower: No
Fast cooling switch:Yes
Fast freezing function:Yes
Temperature Controlled Drawer:No
Humidity Control Drawer:No
Number of Door Bins - Refrigerator:3
Door bin adjustability - Refrigerator: Yes
Tilt-out door bins in fridge:No
Gallon wide door bins:Yes
Number of Gallon storage: 1
Motorized Shelf: No
Material of the shelves: Safety glass
Door opened indicator freezer:No
Automatic motor-driven ice-maker: No
Fuse protection:10 A
Voltage: 220-240 V
Frequency: 50 Hz
Storage Period in Event of Power Failure (h):9 h
Door panel options: Not possible
ENERGY STAR® certified: No
Plug type: Gardy plug w/ earthing
Required cutout/niche size for installation (in):x
Dimensions of the packed product: 72.45 x 24.01 x 25.19
Net weight:113.000 lbs
Gross weight: 122.000 lbs



Series 2, built-in fridge-freezer with freezer at bottom, 177.2 x 54.1 cm, sliding hinge KIV86NSE0

The spacious built-in fridge-freezer combination with LowFrost provides optimal food storage and ice formation is significantly reduced.

- Based on the results of the standard 24-hour test. Actual consumption depends on usage/position of the appliance.

Environment and Safety

Installation

General Information

Performance and consumption

- Energy Class: E
- Total Volume: 267 l
- Annual Energy Consumption: 229 kWh/a
- Fast Freeze Facility
- Noise Level : 35 dB , B Class

Design and Styling

- LED interior light in fridge section

Convenience & Safety

- LED electronic control
- Super Cooling: automatic deactivation
- Acoustic open door warning system
- Automatic defrost in fridge section

Fridge Compartment

- Net Fridge Volume : 183 l
- 4 PC safety glass shelves of which 3 are height adjustable
- 3 door bins, thereof 1 door bin(s) high

Freshness System

- 1 MultiBox - Transparent drawer with a corrugated bottom, ideal for storing fruits and vegetables.

Freezer

- Net Freezer Volume : 84 l
- Freezing capacity 24h: 4.2 kg
- Temperature rise time : 9 H
- Low Frost
- 3 transparent freezer drawers
- No warning system in freezer section
- Super Freezing: Manual/automatic activation

Dimensions

- Appliance Dimensions (H x W x D): 177.2 cm x 54.1 cm x 54.8 cm
- Niche Dimension (H x W x D): 177.5 cm x 56.0 cm x 55.0 cm

Technical Information

- Nominal voltage: 220 - 240 V
- Climate Class: SN-ST
- Door right hinged, reversible
- Height adjustable front feet
- Length of power cord: 230 cm

Accessories

- ice cube tray
- ice cube tray

Country Specific Options

**Series 2, built-in fridge-freezer with
freezer at bottom, 177.2 x 54.1 cm,
sliding hinge
KIV86NSE0**

measurements in mm

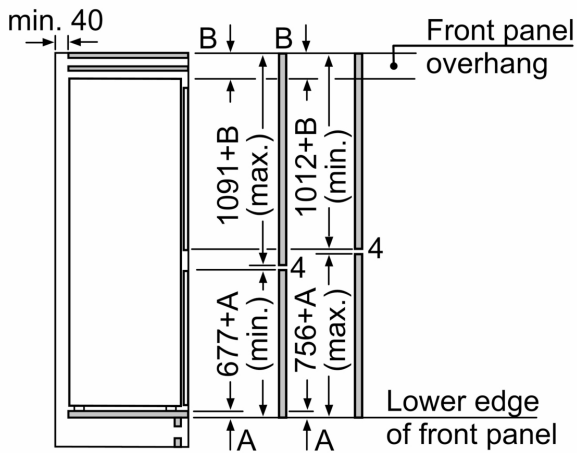
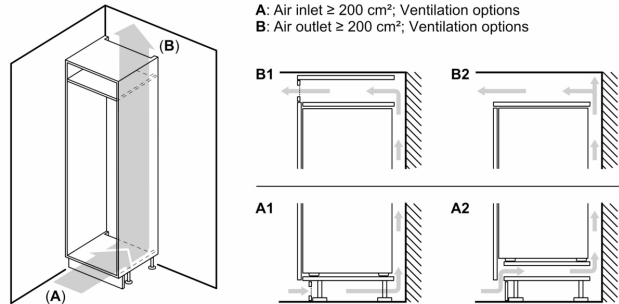
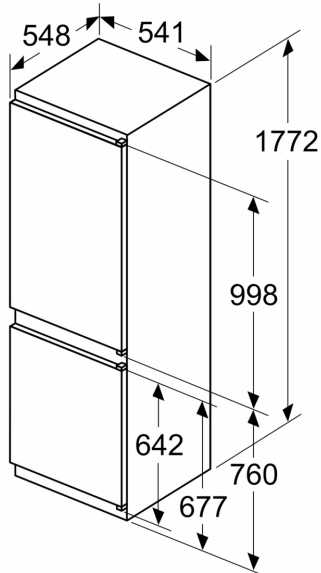

Measurements in mm

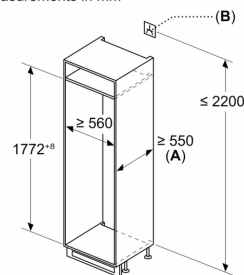

A: $\geq 560 \text{ mm}$ (recommended)
B: Socket

The specified unit door dimensions
are valid for a door gap of 4 mm.

measurements in mm