

## iQ700, Built-in warming drawer, 60 x 14 cm, Matt Black BI910C1M1



The intelligent touchControl multifunctional warming drawer with Home Connect for control at any time from anywhere.

- ✓ Matt Edition – the understated elegance of black matte appliances.
- ✓ Intuitive touch control
- ✓ push&pull – No-handle drawer that’s easy to open and close.
- ✓ Home Connect – Control the multifunctional warming drawer at any time from wherever you want.
- ✓ Drawer installation - Ideal combination to a 45cm compact appliance.

### Optional accessories

HZ32WA00 wireless roastingSensor

### Features

#### Technical Data

Design: ..... Built-in  
 Maximum number of espresso cups: ..... 64  
 Dimensions: ..... 140x594x518 mm  
 Dimensions of the packed product (HxWxD): .....260x650x700 mm  
 Required niche size for installation (HxWxD): ... 140 x 560 x 550 mm  
 Type of control setting and signalling devices: ..... touch control, Via app  
 Time control: ..... No  
 Fuse protection: ..... 10 A  
 Voltage: .....220-240 V  
 Frequency: .....50-60 Hz  
 Plug type: ..... Gardy plug w/ earthing  
 Required cutout/niche size for installation (in): ..... x  
 Dimensions of the packed product: ..... 10.23 x 25.59 x 27.55  
 Net weight: ..... 41.000 lbs  
 Gross weight: ..... 46.000 lbs  
 Length electrical supply cord: ..... 175 cm  
 Required niche size for installation (HxWxD): ... 140 x 560 x 550 mm  
 Dimensions: ..... 140x594x518 mm  
 Dimensions of the packed product (HxWxD): .....260x650x700 mm  
 Net weight: ..... 18.7 kg  
 Gross weight: ..... 20.8 kg



## iQ700, Built-in warming drawer, 60 x 14 cm, Matt Black BI910C1M1

### Features

- Multifunctional warming drawer with 1 heating functions: Gentle heating, Keep warm, plate warming, cup warming

#### Design:

- Matt Surface
- Touch Control illuminated
- Touch key operation
- Glass plate made of toughened glass

#### Comfort:

- User-friendly electronics: extremely
- easy and comfortable operation
- Cavity volume: 20 l
- Loading up to 25 kg
- Max. loading espresso cups: 64 PC or Max. loading plates: 12 PC
- Temperature control in 4 levels: ca. 30°C - 80°C (glass surface temperature)
- push&pull opening without handle
- Favourites button - manage via Home Connect app
- Home Connect ready on Wi-Fi

#### Technical Information

- Length of mains cable: 175 cm
- Total connected load electric: 0.82 KW
- Nominal voltage: 220 - 240 V

#### Dimensions:

- Appliance dimension (HxWxD): 140 mm x 594 mm x 518 mm
- Niche dimension (HxWxD): 140 mm x 560 mm - 568 mm x 550 mm
- We recommend you to choose complementary products within iQ700, in order to assure an optimal design combination of your Built-In appliances.
- "Please reference the built-in dimensions provided in the installation drawing"

**iQ700, Built-in warming drawer,  
60 x 14 cm, Matt Black  
BI910C1M1**

Dimensioned drawings

Measurements in mm

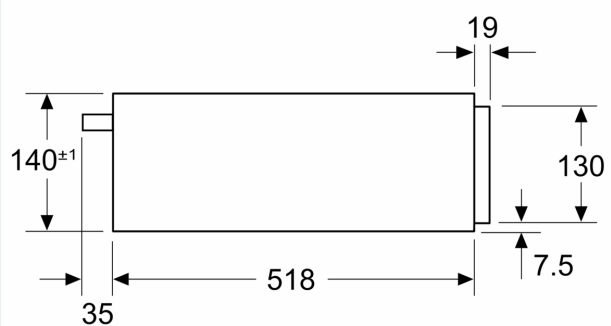

Measurements in mm

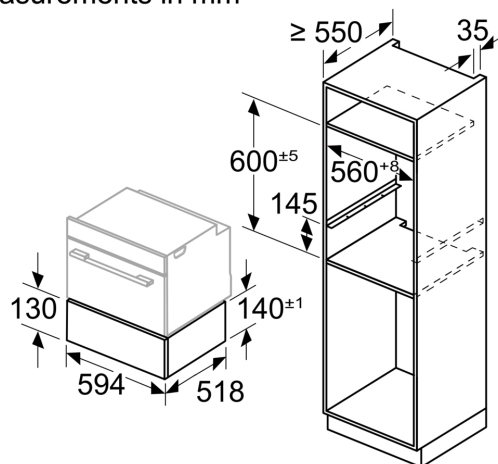

For the combined installation of some electrical appliances, support frames are required