

**iQ500, French Door Bottom freezer, multi door, 183 x 90.5 cm, BlackSteel, Total noFrost KF96DAXEA**



The Multi Door fridge freezer combination: where freshness meets intelligent design. Longer fresh with hyperFresh XXL <0°C>, no defrosting anymore due to Total noFrost, filtered water and ice at the push of a button.

- ✓ Quick ice & Water dispenser with tap connection: Freshly filtered water any time and up to 5kg ice daily.
- ✓ bigCapacity: More storage space for your groceries.
- ✓ Total noFrost: Never defrost your freezer again and bid farewell to water drops on the fridge backwall.
- ✓ Metal backwall with multiAirflow: Evenly cooled food and drinks on all levels.
- ✓ hyperFresh <0°C>: More space for fruit and vegetables. A cold climate for fish and meat.

**Features**

**Technical Data**

Energy Efficiency Class (Regulation (EU) 2017/1369) <sup>1</sup> :	.....E
Average annual energy consumption in kilowatt hour per year (kWh/a) <sup>2</sup> :	..... 327 kWh/annum
Sum of volume of frozen compartments:	..... 199 l
Sum of volume of chill compartments:	..... 375 l
Airborne acoustical noise emissions :	..... 39 dB(A) re 1pW
Airborne acoustical noise emission class:	.....C
Design:	..... Free-standing
Number of compressors:	..... 1
Number of independent cooling systems:	..... 1
Width of the appliance:	..... 905 mm
Height:	..... 1830 mm
Depth:	..... 731 mm
Net weight:	..... 138.6 kg
Door panel options:	.....Not possible
Door hinge:	.....left and right
Number of Adjustable Shelves in fridge compartment:	..... 4
Shelves for Bottles:	.....Yes
Frost free system:	.....Fridge and freezer
Interior ventilator:	..... Yes
Reversible Door Hinge:	..... No
Length electrical supply cord:	..... 240 cm
Noise level:	..... 38 dB(A) re 1pW
Multi-Flow Air Tower:	..... Yes
Fast cooling switch:	..... Yes
Fast freezing function:	.....Yes
Temperature Controlled Drawer:	.....No
Humidity Control Drawer:	..... No
Number of Door Bins - Refrigerator:	.....4
Door bin adjustability - Refrigerator:	.....Yes
Tilt-out door bins in fridge:	..... Yes
Gallon wide door bins:	.....Yes
Number of Gallon storage:	..... 1
Motorized Shelf:	..... No
Material of the shelves:	..... Safety glass
Door opened indicator freezer:	..... Yes
Automatic motor-driven ice-maker:	.....Yes
Fuse protection:	..... 10 A
Voltage:	.....220-240 V
Frequency:	.....50-60 Hz
Storage Period in Event of Power Failure (h):	..... 11 h
Door panel options:	.....Not possible
Noise level:	..... 38 dB(A) re 1pW
ENERGY STAR® certified:	..... No
Plug type:	..... Gardy plug w/ earthing
Required cutout/niche size for installation (in):	..... 1 /

<sup>1</sup> Scale of Energy Efficiency Classes from A to G

<sup>2</sup> Based on the results of the standard 24-hour test. Actual consumption depends on usage/position of the appliance.

Dimensions of the packed product: ..... 74.99 x 39.29 x 30.23  
Net weight: ..... 305.000 lbs  
Gross weight: ..... 331.000 lbs



## iQ500, French Door Bottom freezer, multi door, 183 x 90.5 cm, BlackSteel, Total noFrost KF96DAXEA

### Features

- noFrost
- Brushed black steel anti-fingerprint Doors

#### Performance and consumption

- Energy Class: E
- Total Volume: 574 l
- Annual Energy Consumption: 327 kWh/a
- Fast Freeze Facility
- Noise Level : 39 dB , C Class

#### Design and Styling

- Doors Brushed black steel anti-fingerprint, side panels cast iron
- LED interior light in fridge section
- Metal backwall with multi airflow
- Interior with metal applications

#### Convenience & Safety

- Total noFrost - frost-free freezer and no condensation in fridge
- 7 segment electronic control
- Wi-Fi
- Lockable
- Child lock, Sabbath mode, Economy setting, Holiday mode
- Connected appliance: Remote Monitoring and Control, iService Remote
- Separate temperature control for cooling and freezing section
- Super Cooling: automatic deactivation
- Super Freezing: Yes (obsolete)
- Acoustic warning system, Optical warning system Door open
- Acoustic Warning System, Warning System by temperature increase

#### Ice and Water

- Illuminated water and ice / crushed ice dispenser
- Automatic ice cube maker
- Water filter
- Drinking Water Dispenser
- Crushed ice
- Ice cube
- Connection Length (water supply):200 cm

#### Fridge Compartment

- Net Fridge Volume : 375 l
- Multi Airflow-System
- Water dispenser: yes, direct conn.water-tap
- 5 PC safety glass shelves of which 4 are height adjustable
- 1 door bin(s) high, 3 door bin(s) small
- Bottle storage: FlexShelf
- Dairy compartment

#### Freshness System

- 1 hyperFresh «0°C» box - fish and meat stay fresh for longer.

- 1 hyperFresh box with adjustable humidity on wheels - keeps fruit and vegetables fresh for longer.

#### Freezer

- Net Freezer Volume : 199 l
- Net 4\* compartment volume : 192 l
- Freezing capacity 24h: 16 kg
- freezerLight
- 6 transparent freezer drawers
- LED Illumination in freezer section

#### Dimensions

- Appliance Dimensions ( H x W x D): 183 cm x 90.5 cm x 73.1 cm

#### Technical Information

- 4 wheels for easier transport, 3 of them height adjustable.
- Nominal voltage: 220 - 240 V
- Climate Class: SN-T
- Length of power cord: 240 cm

#### Accessories

#### Country Specific Options

- Based on the results of the standard 24-hour test. Actual consumption depends on usage/position of the appliance.

**iQ500, French Door Bottom freezer, multi door, 183 x 90.5 cm, BlackSteel, Total noFrost KF96DAXEA**

Dimensioned drawings

Measurements in mm

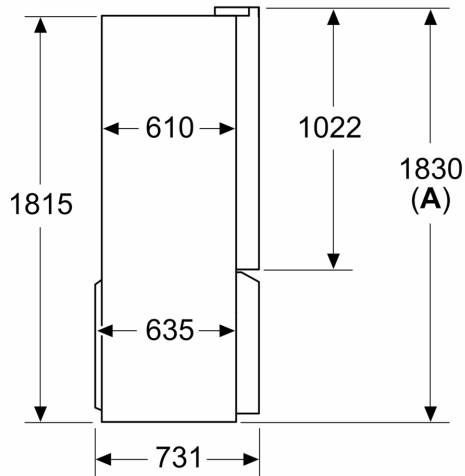

**A:** Front is adjustable 1830–1847 mm, with front levelling feet fully extended

Measurements in mm

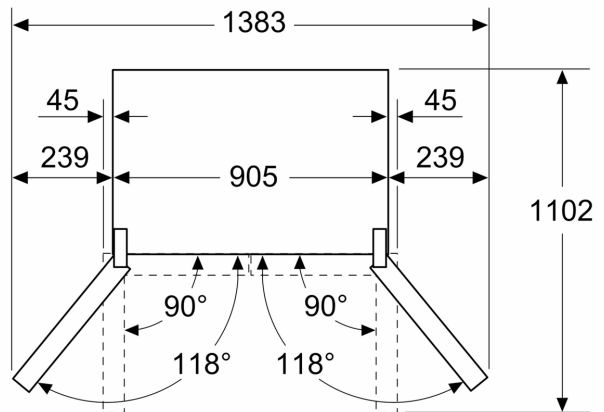

Measurements in mm

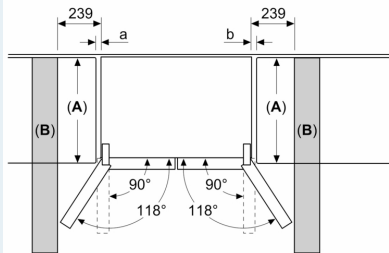

A	a	b
≤ 600	0	0
600 < A ≤ 650	45	45
650 < A ≤ 700	60	60
> 700	239	239

**A:** Kitchen cabinet or worktop depth

**B:** Wall  
Drawers can be pulled and taken out with door open to 90°

Measurements in mm

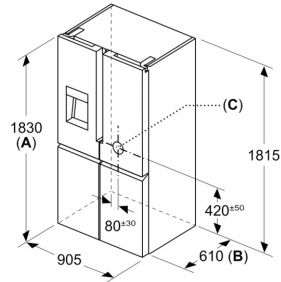

**A:** Front is adjustable 1830–1847 mm, with front levelling feet fully extended

**B:** Add 25 mm for fixed spacers on back

**C:** Water connection position