

iQ100, built-in fridge-freezer with freezer at bottom, 177.2 x 54.1 cm, sliding hinge KI86NNSE0



Optional accessories	
KS6BZR00	Bottle Rack
KSGGZM00	Butter box

- Built-in fridge-freezer with noFrost for no defrosting effort**
- ✓ Fresh: Convenient storage for your fruit and vegetables.
 - ✓ safetyGlass shelves: Extra strong and easy to clean safety glass.
 - ✓ Made in Germany – A promise of top quality, state-of-the-art design and innovative features.
 - ✓ Noise Class B: The quiet appliances are not louder than rustling leaves.
 - ✓ Extended Spare Parts availability: Powering appliance endurance.

Features

Technical Data	
Energy Efficiency Class (Regulation (EU) 2017/1369) ¹ :	E
Average annual energy consumption in kilowatt hour per year (kWh/a) ² :	234 kWh/annum
Sum of volume of frozen compartments:	76 l
Sum of volume of chill compartments:	184 l
Airborne acoustical noise emissions :	35 dB(A) re 1 pW
Airborne acoustical noise emission class:	B
Design:	Built-in
Number of compressors:	1
Number of independent cooling systems:	1
Width of the appliance:	541 mm
Height:	1772 mm
Depth:	548 mm
Net weight:	51.5 kg
Required niche size for installation (HxWxD):	1775x560x550 mm
Door panel options:	Not possible
Door hinge:	Right reversible
Number of Adjustable Shelves in fridge compartment:	3
Shelves for Bottles:	No
Frost free system:	Freezer
Interior ventilator:	No
Reversible Door Hinge:	Yes
Length electrical supply cord:	230 cm
Multi-Flow Air Tower:	No
Fast cooling switch:	Yes
Fast freezing function:	Yes
Temperature Controlled Drawer:	No
Humidity Control Drawer:	No
Number of Door Bins - Refrigerator:	3
Door bin adjustability - Refrigerator:	Yes
Tilt-out door bins in fridge:	No
Gallon wide door bins:	Yes
Number of Gallon storage:	1
Motorized Shelf:	No
Material of the shelves:	Safety glass
Door opened indicator freezer:	No
Automatic motor-driven ice-maker:	No
Fuse protection:	10 A
Voltage:	220-240 V
Frequency:	50 Hz
Storage Period in Event of Power Failure (h):	10 h
Door panel options:	Not possible
ENERGY STAR® certified:	No
Plug type:	Gardy plug w/ earthing
Required cutout/niche size for installation (in):	x
Dimensions of the packed product:	72.45 x 24.01 x 25.19
Net weight:	113.000 lbs
Gross weight:	123.000 lbs

¹ Scale of Energy Efficiency Classes from A to G
² Based on the results of the standard 24-hour test. Actual consumption depends on usage/position of the appliance.



iQ100, built-in fridge-freezer with freezer at bottom, 177.2 x 54.1 cm, sliding hinge KI86NNSE0

Features

Performance and consumption

- Energy Class: E
- Total Volume: 260 l
- Annual Energy Consumption: 234 kWh/a
- Fast Freeze Facility
- Noise Level : 35 dB , B Class

Design and Styling

- LED interior light in fridge section

Convenience & Safety

- No Frost
- LED electronic control
- Optical and acoustic door open warning system
- Super Cooling: automatic deactivation

Fridge Compartment

- Net fridge volume: 184 l
- 3 door bins, thereof 1 door bin(s) high

Freshness System

- 1 Fresh box

Freezer

- Net Freezer Volume : 76 l
- Freezing capacity 24h: 4 kg
- Temperature rise time : 10 H
- 3 transparent freezer drawers
- No warning system in freezer section
- Super Freezing: Manual/automatic activation

Dimensions

- Appliance Dimensions (H x W x D): 177.2 cm x 54.1 cm x 54.8 cm
- Niche Dimension (H x W x D): 177.5 cm x 56.0 cm x 55.0 cm

Technical Information

- Door right hinged, reversible
- Nominal voltage: 220 - 240 V
- Climate Class: SN-ST
- Length of power cord: 230 cm

Accessories

- ice cube tray
- ice cube tray

Country Specific Options

- Based on the results of the standard 24-hour test. Actual consumption depends on usage/position of the appliance.

Environment and Safety

Installation

General Information

**iQ100, built-in fridge-freezer with
freezer at bottom, 177.2 x 54.1
cm, sliding hinge
KI86NNSE0**

Dimensioned drawings

measurements in mm

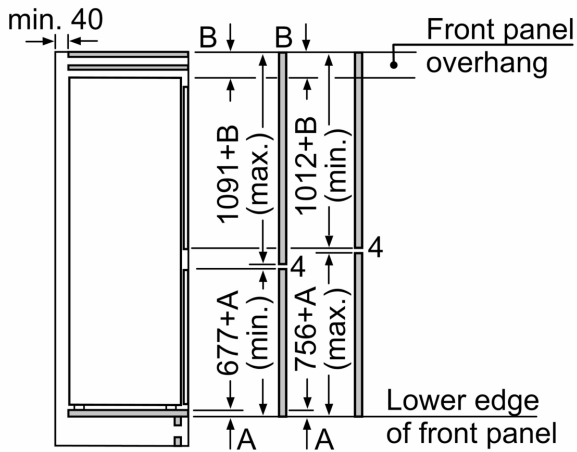
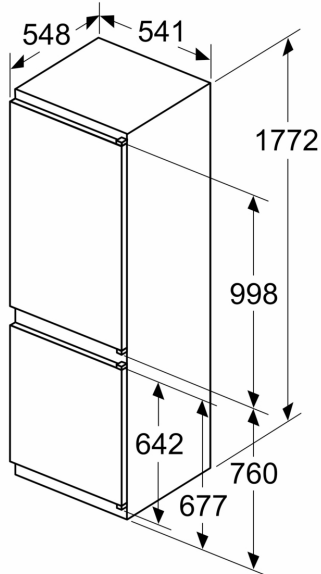

The specified unit door dimensions are valid for a door gap of 4 mm.
measurements in mm

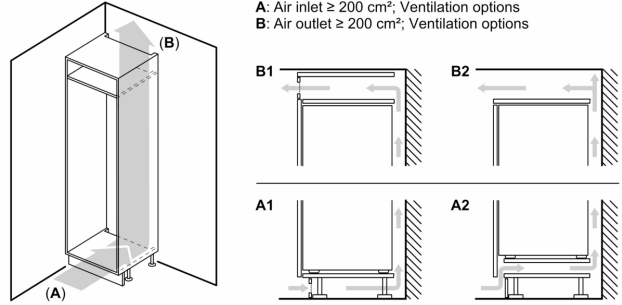

Measurements in mm

