

## iQ500, built-in fridge-freezer with freezer at bottom, 177.2 x 55.8 cm, soft close flat hinge KI86NSDB0



Built-in fridge-freezer with hyperFresh  $<0^{\circ}\text{C}>$  to keep fruit and vegetables fresh longer and LED lights and freezerLight for brilliant illumination of the fridge's and freezer interior.

- ✓ hyperFresh  $<0^{\circ}\text{C}>$ : More space for fruit and vegetables. A cold climate for fish and meat.
- ✓ autoAirflow – Ideal air circulation and even cooling at all levels for longer freshness.
- ✓ flexShelf: Optimize your fridge space by sliding the shelf out of the way.
- ✓ freezerLight: Clever freezer illumination.
- ✓ doorAlarm: Reminds you to close the door and keep the cold inside.

### Features

#### Technical Data

Energy Efficiency Class (Regulation (EU) 2017/1369) <sup>1</sup> : .....	B
Average annual energy consumption in kilowatt hour per year (kWh/a) <sup>2</sup> : .....	120 kWh/annum
Sum of volume of frozen compartments: .....	76 l
Sum of volume of chill compartments: .....	184 l
Airborne acoustical noise emissions : .....	33 dB(A) re 1pW
Airborne acoustical noise emission class: .....	B
Design: .....	Built-in
Number of compressors: .....	1
Number of independent cooling systems: .....	2
Width of the appliance: .....	558 mm
Height: .....	1772 mm
Depth: .....	548 mm
Net weight: .....	68.0 kg
Required niche size for installation (HxWxD): ....	1775x560x550 mm
Door panel options: .....	Not possible
Door hinge: .....	Right reversible
Number of Adjustable Shelves in fridge compartment: .....	2
Shelves for Bottles: .....	Yes
Frost free system: .....	Freezer
Interior ventilator: .....	No
Reversible Door Hinge: .....	Yes
Length electrical supply cord: .....	230 cm
Multi-Flow Air Tower: .....	No
Fast cooling switch: .....	Yes
Fast freezing function: .....	Yes
Temperature Controlled Drawer: .....	No
Humidity Control Drawer: .....	No
Number of Door Bins - Refrigerator: .....	2
Door bin adjustability - Refrigerator: .....	Yes
Tilt-out door bins in fridge: .....	No
Gallon wide door bins: .....	Yes
Number of Gallon storage: .....	1
Motorized Shelf: .....	No
Material of the shelves: .....	Safety glass
Door opened indicator freezer: .....	No
Automatic motor-driven ice-maker: .....	No
Fuse protection: ....	10 A
Voltage: .....	220-240 V
Frequency: .....	50 Hz
Storage Period in Event of Power Failure (h): .....	13 h
Door panel options: .....	Not possible
ENERGY STAR® certified: .....	No
Plug type: .....	Gardy plug w/ earthing
Required cutout/niche size for installation (in): .....	x
Dimensions of the packed product: .....	72.44 x 24.01 x 25.19

### Optional accessories

KSGGZM00 Butter box

<sup>1</sup> Scale of Energy Efficiency Classes from A to G

<sup>2</sup> Based on the results of the standard 24-hour test. Actual consumption depends on usage/position of the appliance.

Net weight: ..... 150.000 lbs  
Gross weight: ..... 159.000 lbs



## iQ500, built-in fridge-freezer with freezer at bottom, 177.2 x 55.8 cm, soft close flat hinge KI86NSDB0

### Features

- Built-in-refrigerator 2-door, Bottom Fre
- easy Installation
- Flat hinge, Soft closing: yes

#### Performance and consumption

- Energy Class: B
- Total Volume: 260 l
- Annual Energy Consumption: 120 kWh/a
- Fast Freeze Facility
- Noise Level : 33 dB , B Class

#### Design and Styling

- LED interior light in fridge section
- freezerLight

#### Convenience & Safety

- No Frost
- Twin LED electronic control
- Super Cooling: automatic deactivation
- Optical and acoustic door open warning system

#### Fridge Compartment

- Net Fridge Volume : 184 l
- 4 PC safety glass shelves of which 2 are height adjustable
- 1 door bin(s) high
- 3 door bins, thereof 1 door bin(s) high
- Dairy compartment
- Bottle storage: Bottle grid
- 1 door bin(s) high, 1 door bin(s) small

#### Freshness System

- 1 hyperFresh box with adjustable humidity - keeps fruit and vegetables fresh for longer.
- 1 hyperFresh <0°C> box - keeps fish and meat longer fresh

#### Freezer

- Net Freezer Volume : 76 l
- Freezing capacity 24h: 8 kg
- Temperature rise time : 13 H
- Super Freezing: Manual/automatic activation
- 3 transparent freezer drawers

#### Dimensions

- Appliance Dimensions ( H x W x D): 177.2 cm x 55.8 cm x 54.8 cm
- Niche Dimension (H x W x D): 177.5 cm x 56.0 cm x 55.0 cm

#### Technical Information

- Door right hinged, reversible
- Climate Class: SN-ST
- Nominal voltage: 220 - 240 V
- Length of power cord: 230 cm

#### Accessories

- ice cube tray
- ice cube tray

#### Country Specific Options

- Based on the results of the standard 24-hour test. Actual consumption depends on usage/position of the appliance.

#### Environment and Safety

#### Installation

#### General Information

- 1 foldable garage plate1 PC
- side-by-side capable
- Side-by-Side Enabler: no

**iQ500, built-in fridge-freezer with freezer at bottom, 177.2 x 55.8 cm, soft close flat hinge KI86NSDB0**

Dimensioned drawings

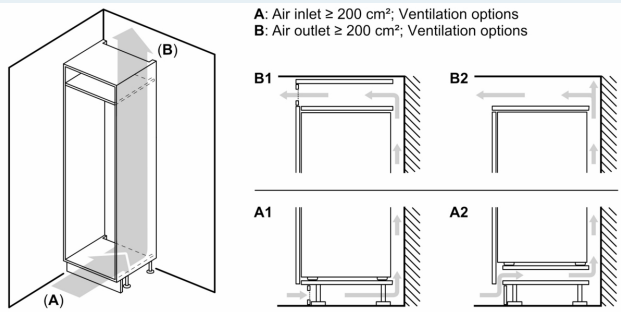

**Maximal permissible weight of the unit fronts**

Fitted unit fronts that exceed the permissible weight may cause damage and result in functional impairment of the hinges

$\Delta$  Weight  
 A: Appliance door height including hinges in mm

B: Undamped hinge, unit front in kg  
 C: Damped hinge, unit front in kg  
 D: Additional possible load in kg with heavy load kit

A	B	C	D
1500-1750	22	22	
720-1400	19	19	B+5 / C+5
A1	15	19	
A2	15	19	

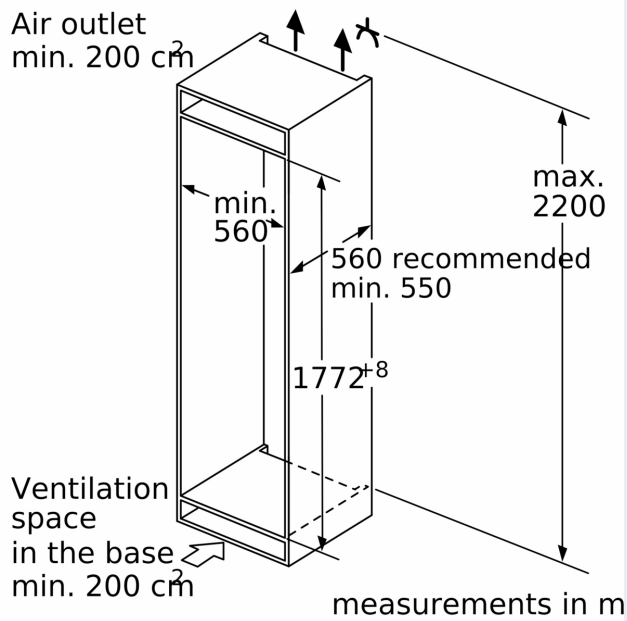
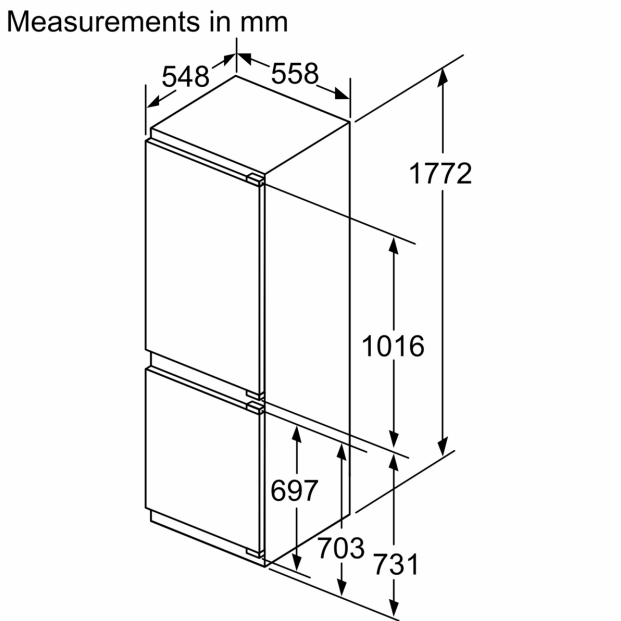

Dimensioned drawings

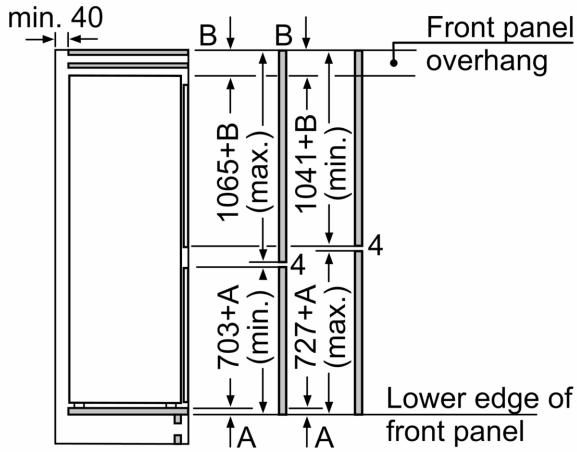

The specified unit door dimensions are valid for a door gap of 4 mm.  
 measurements in mm

measurements in mm  
 Recommended gap dimensions for flat hinges

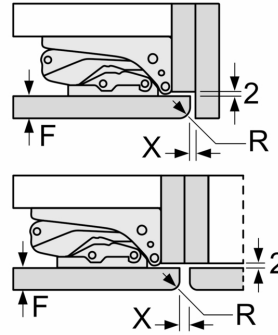

F	R	X
16-19	0-3	2.5
20	0-1	3
	2-3	2.5
21	0-1	3
	2-3	2.5
22	0	4
	1	3.5
	2-3	3

The gap dimensions recommended in the table must be adhered to in order to ensure that appliance doors do not collide with anything when they are opened, and to avoid causing damage to kitchen units.