

iQ100, built-in fridge-freezer with freezer at bottom, 193.5 x 54.1 cm, sliding hinge KI96NNSE0



The extra large built-in fridge freezer with 11% more cooling volume including Fresh Box drawer for fruit and vegetables, No Frost and fast cooling and freezing functions for optimal storage.

- ✓ Large volume: 11% more space to store your entire weekly groceries.
- ✓ LED light: Even lighting throughout the interior allows for easy visibility of all items.
- ✓ autoAirflow – Ideal air circulation and even cooling at all levels for longer freshness.
- ✓ noFrost: Never defrost your freezer again.
- ✓ superFreezing: Quickly freezes even large amounts of food.

Features

Technical Data

Energy Efficiency Class (Regulation (EU) 2017/1369) ¹ :	E
Average annual energy consumption in kilowatt hour per year (kWh/a) ² :	231 kWh/annum
Sum of volume of frozen compartments:	75 l
Sum of volume of chill compartments:	215 l
Airborne acoustical noise emissions :	34 dB(A) re 1 pW
Airborne acoustical noise emission class:	B
Design:	Built-in
Number of compressors:	1
Number of independent cooling systems:	2
Width of the appliance:	541 mm
Height:	1935 mm
Depth:	548 mm
Net weight:	56.3 kg
Required niche size for installation (HxWxD):	1940x560x550 mm
Door panel options:	Not possible
Door hinge:	Right reversible
Number of Adjustable Shelves in fridge compartment:	4
Shelves for Bottles:	No
Frost free system:	Freezer
Interior ventilator:	No
Reversible Door Hinge:	Yes
Length electrical supply cord:	230 cm
Multi-Flow Air Tower:	No
Fast cooling switch:	Yes
Fast freezing function:	Yes
Temperature Controlled Drawer:	No
Humidity Control Drawer:	No
Number of Door Bins - Refrigerator:	4
Door bin adjustability - Refrigerator:	Yes
Tilt-out door bins in fridge:	Yes
Gallon wide door bins:	Yes
Number of Gallon storage:	1
Motorized Shelf:	No
Material of the shelves:	Safety glass
Door opened indicator freezer:	No
Automatic motor-driven ice-maker:	No
Fuse protection:	10 A
Voltage:	220-240 V
Frequency:	50 Hz
Storage Period in Event of Power Failure (h):	10 h
Door panel options:	Not possible
ENERGY STAR [®] certified:	No
Plug type:	Gardy plug w/ earthing
Required cutout/niche size for installation (in):	x
Dimensions of the packed product:	79.52 x 24.40 x 24.80
Net weight:	124.000 lbs ¹

Optional accessories

KS6BZR00	Bottle Rack
KSGGZM00	Butter box

¹ Scale of Energy Efficiency Classes from A to G

² Based on the results of the standard 24-hour test. Actual consumption depends on usage/position of the appliance.

Gross weight: 134.000 lbs



iQ100, built-in fridge-freezer with freezer at bottom, 193.5 x 54.1 cm, sliding hinge KI96NNSE0

Features	
<p>Performance and consumption</p> <ul style="list-style-type: none"> • Energy Class: E • Total Volume: 290 l • Annual Energy Consumption: 231 kWh/a • Noise Level : 34 dB , B Class <p>Design and Styling</p> <ul style="list-style-type: none"> • LED interior light in fridge section • Built-in-refrigerator 2-door, Bottom Fre <p>Convenience & Safety</p> <ul style="list-style-type: none"> • No Frost • Fast Freeze Facility • Twin LED electronic control • Two Cooling Systems • Super Cooling: automatic deactivation • Optical and acoustic door open warning system • Automatic defrost in fridge section <p>Fridge Compartment</p> <ul style="list-style-type: none"> • Net Fridge Volume : 215 l • 5 safety glass shelves, thereof 4 height adjustable, Standard • 1 door bin(s) high, 3 door bin(s) small <p>Freshness System</p> <ul style="list-style-type: none"> • 1 Fresh box <p>Freezer</p> <ul style="list-style-type: none"> • Net Freezer Volume : 75 l • Freezing capacity 24h: 7.5 kg • Temperature rise time : 10 H • 3 transparent freezer drawers <p>Dimensions</p> <ul style="list-style-type: none"> • Appliance Dimensions (H x W x D): 193.5 cm x 54.1 cm x 54.8 cm • Niche Dimension (H x W x D): 194.0 cm x 56.0 cm x 55.0 cm <p>Technical Information</p> <ul style="list-style-type: none"> • Door right hinged, reversible • Length of power cord: 230 cm • Climate Class: SN-ST • Nominal voltage: 220 - 240 V <p>Accessories</p> <ul style="list-style-type: none"> • ice cube tray • ice cube tray <p>Country Specific Options</p> <ul style="list-style-type: none"> • Based on the results of the standard 24-hour test. Actual consumption depends on usage/position of the appliance. <p>Environment and Safety</p> <p>Installation</p>	<p>General Information</p> <ul style="list-style-type: none"> • Without Illumination • side-by-side capable • Side-by-Side Enabler: no

iQ100, built-in fridge-freezer with freezer at bottom, 193.5 x 54.1 cm, sliding hinge KI96NNSE0

Dimensioned drawings

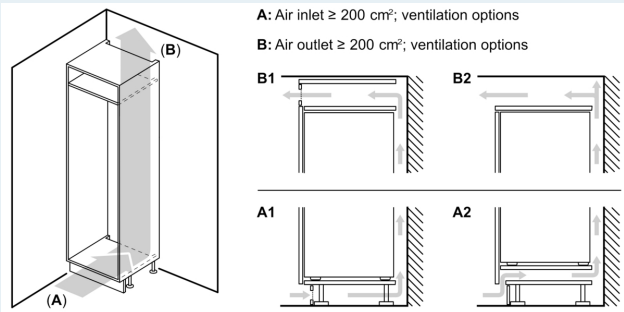

Measurements in mm

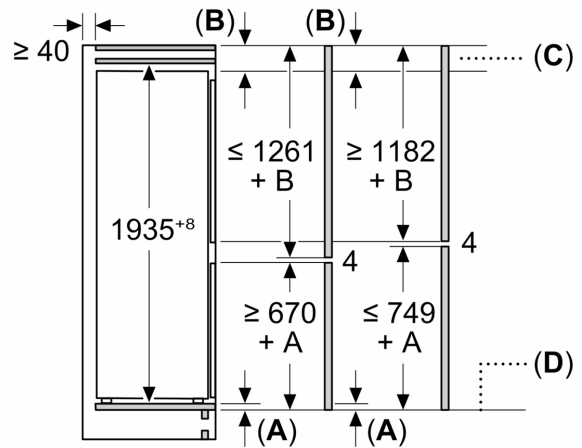

C: Front panel overhang

D: Lower edge of front panel

Measurements in mm

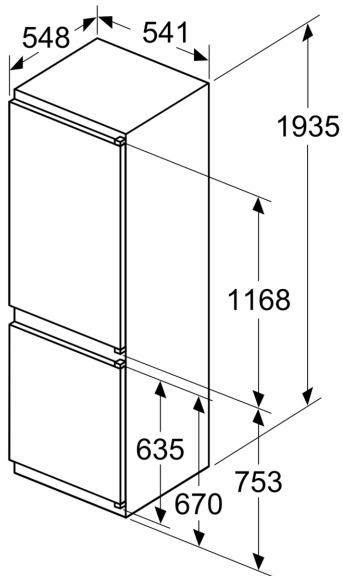

Measurements in mm

