

iQ500, wall-mounted cooker hood, 90 cm, Matt black LC97BDN60



Optional accessories

LZ11FBB16	Long-life Clean Air odor filter (repl.)
LZ11FBI16	Long-life Clean Air recirculation kit
LZ11FBK62	Chimney extension 1000 mm

- ✓ iQdrive Motor: Powerful extraction with low noise for a quiet, efficient cooking experience.
- ✓ Intelligent hood automatic: automatically adjusts hood extraction based on hob settings.
- ✓ LED light: Bright, clear illumination with adjustable color temperature.
- ✓ touchControl: For a quick, easy and uncomplicated operation.
- ✓ Black matt finish: Modern coating with fewer visible fingerprints.

Features

Technical Data

Typology:	Wall-mounted
Length electrical supply cord:	130 cm
Height of product, without chimney:	60 mm
Net weight:	13.9 kg
Type of control:	Electronic
Number of speed settings:	3-stages + intensive setting
Maximum output air extraction:	399 m ³ /h
Boost position output recirculating:	677.0 m ³ /h
Maximum output recirculating air:	410 m ³ /h
Boost position air extraction:	699 m ³ /h
Number of lights:	2
Noise level:	56 dB(A) re 1pW
Diameter of air outlet:	150 mm
Grease filter material:	Washable stainless steel
Odour filter:	No
Operating Mode:	Convertible
Type of lamps used:	LED
Grease filter type:	Kassette
Clean filter reminders:	No
Connection rating:	115 W
Voltage:	220-240 V
Frequency:	50; 60 Hz
Plug type:	Gardy plug w/ earthing
Installation typology:	Wall-mounted
Body material:	Coil coated steel
Plug type:	Gardy plug w/ earthing
Dimensions of the product, with chimney (if exists) (in):	x x
Dimensions of the packed product:	27.55 x 22.83 x 40.15
Net weight:	31.000 lbs
Gross weight:	45.000 lbs
Motor location:	Integrated motor in hood chimney
No-return airflow flap:	No
Length electrical supply cord:	130 cm
Dimensions of the product, with chimney (if exists):	700x900x500 mm
Dimensions of the packed product (HxWxD):	700x580x1020 mm
Net weight:	13.9 kg
Gross weight:	20.5 kg



iQ500, wall-mounted cooker hood, 90 cm, Matt black LC97BDN60

Features

Design:

- wall-mounted hood
- Suitable for ducted or re-circulated extraction

Core Features:

- iQdrive Motor
- 2 x LED 3W with adjustable colour temperature
- softLight: the lighting elements switch on and off smoothly
- Light dimmer function : the brightness of the lighting elements can be adjusted.
- Colour Temperature: 3500 K
- Light Intensity: 461 lux
- 3 metal grease filter(s)

Comfort Features:

- glass front panel with integrated control elements for an easy operation
- Electronic control via touchControl, backlit
- 3 speeds plus intensive setting
- Automatic reset from intensive to normal setting after 6 min
- Automatic 10 minutes after running

Digital Features:

- Home Connect: operate, monitor and set preferences of your hood via smartphone or tablet (only in countries where Home Connect service is available)
- Cooktop-based Hood Control (works with all Home Connect hobs): automatically activates the hood when cooking, thanks to the WiFi connection of hood and suitable hob
- Intelligent hood automatic: Hood automatically adapts fan speed thanks to hob continuously providing cooking data (works with all current induction hobs with touchSlider; for other Home Connect hobs, the hood can be controlled directly from the hob, provided a connected Home Connect account is available)
- Voice Control enabled via popular voice assistants (only in countries where this service is available)
- Performance Profiles: choose between standard, performance or silence profiles to increase the extraction rate or reduce the fan noise via Home Connect App
- LED light with adjustable light temperature: Allows you to adapt the light temperature to your personal needs via Home Connect App
- Saturation indicator, set and reset function for grease filter and odour filter available via Home Connect app
- After run function: available via Home Connect App
- Interval function: available via Home Connect App
- The Home Connect functionality can be extended by integrating numerous applications from external cooperation partners (partnerships)
- Updateable appliance (available with connected Home Connect account): keep appliance always up to date with latest status of software.

Cleaning Comfort:

- Easy to clean smooth surfaces and materials

- Metal grease filter dishwasher-safe
- Coated surfaces for less fingerprint sensitivity

Exhaust Mode:

- According to EN 61591 and EN/ IEC 60704-2-13 your appliance can achieve the following values in exhaust mode:
 - Speed 1: extraction rate 242 m3/h; noise level 43 dB(A) re1pW
 - Speed 2: extraction rate 335 m3/h; noise level 51 dB(A) re1pW
 - Speed 3: extraction rate 399 m3/h; noise level 56 dB(A) re1pW
 - Intensive Speed 1: extraction rate 699 m3/h; noise level 68 dB (A) re1pW
- Energy Efficiency Class: A++ (at a range of energy efficiency classes from A+++ to D)
- Average Energy Consumption: 24.5 kWh/year
- Blower Efficiency Class: A
- Lighting Efficiency Class: A
- Grease Filtering Efficiency Class: B

Recirculation Mode:

- For recirculation operation Long-life Clean Air recirculation kit (accessory) needed
- The Long-life Clean Air odour filter absorbs intense odours, such as fish, as well as pollen. The lifetime can be extended up to 4 times by refreshing the filter in the oven (for 3 hours at 100°C).
- According to EN 61591 and EN/ IEC 60704-2-13 your appliance can achieve the following values in recirculation mode with Long-life Clean Air recirculation kit (available as optional accessory):
 - Speed 1: extraction rate 239 m3/h; noise level 50 dB(A) re1pW
 - Speed 2: extraction rate 334 m3/h; noise level 59 dB(A) re1pW
 - Speed 3: extraction rate 410 m3/h; noise level 64 dB(A) re1pW
 - Intensive Speed 1: extraction rate 677 m3/h; noise level 73 dB (A) re1pW

Technical Information and Sustainability:

- Consumption data:
- Power rating: 115 W
- Voltage: 220 - 240 V
- Sustainability:
 - Made in Germany: produced at a CO2 neutral production site
 - Environmentally friendly packaging
 - Most efficient blower technology available on the market
 - Available Long-life Clean Air odour filter with extended lifetime up to 4 times

Planning and Installation Information:

- Reduced assembly effort thanks to the easy installation method
- Dimensions exhaust air (HxWxD): 635 mm - 895 mm x 898 mm x 500 mm
- Dimensions recirculating installation (HxWxD): 803 mm - 1080 mm x 898 mm x 500 mm
- Diameter pipe Ø 150 mm
- Electrical cable length 1.3 m

Features

--	--

iQ500, wall-mounted cooker hood, 90 cm, Matt black LC97BDN60

Dimensioned drawings

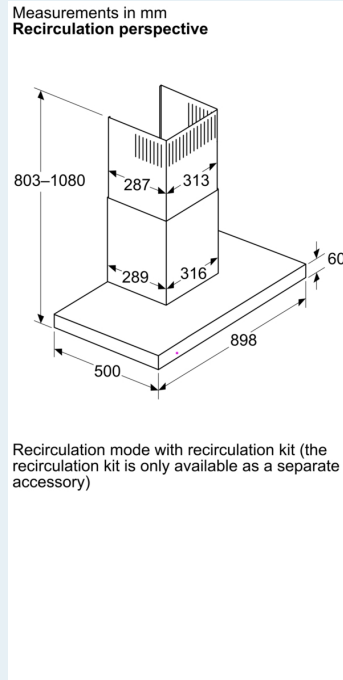
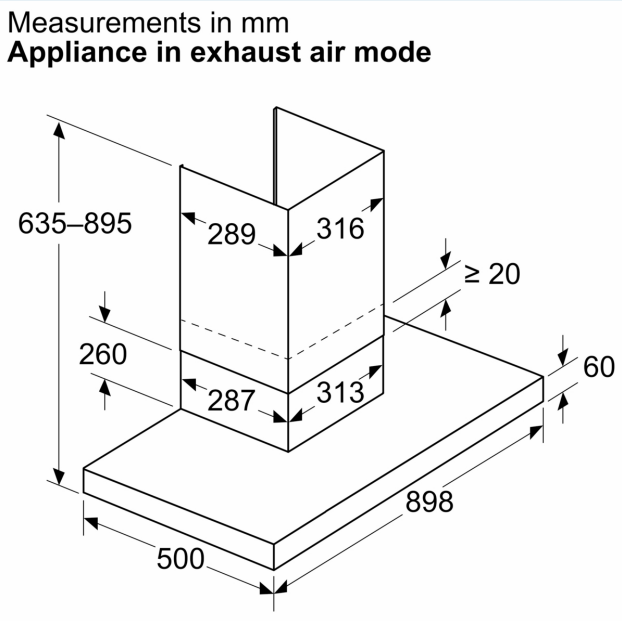
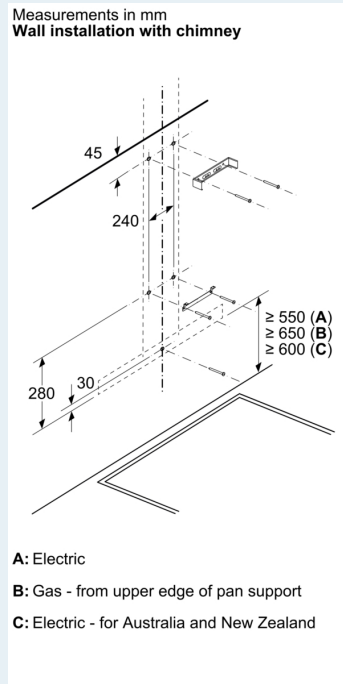
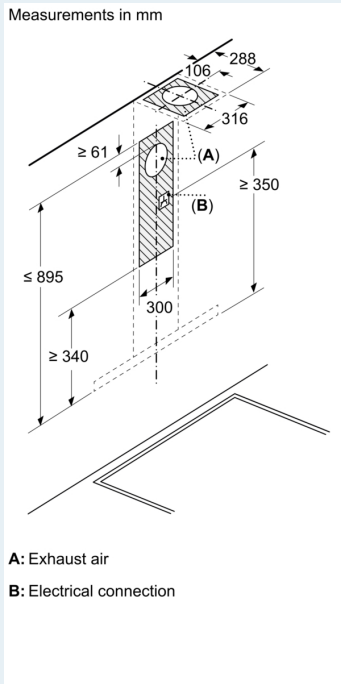

Dimensioned drawings

Measurements in mm
Wall panel depth

