

## iQ700, downdraft hood, 80 cm, clear glass, Black LD88WMM66

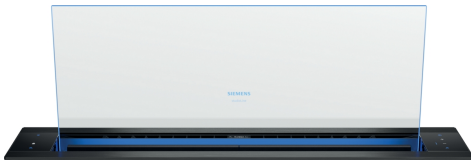

### Optional accessories

HZ9VDSB1 90° flat duct bend horizontal, HZ9VDSB2 90° flat duct L vertical, HZ9VDSI0 Adapter round-flat, HZ9VDSI1 90° Adapter round-flat, HZ9VDSM1 Straight tube 500mm, HZ9VDSM2 Straight tube 1000mm, HZ9VDS51 Connector sleeve (female), LZ21WWB16 Clean Air Plus odor filter (replacement), LZ21WWI16 Clean Air Plus recirculation kit, LZ21WWJ11 Long Life recirculation kit, LZ21WWM11 Installation kit remote motor, LZ28WWY12 Mounting kit for seamless installation, LZ31WWX11 Flat duct adapt.round 90° DN150 Metal, LZ31XX11 Aluflex pipe cyl. 150

The seamlessly designed glassdraftAir is only visible when in use, with an impressive performance thanks to the new Guided Air technology.

- ✓ Guided Air : Excellent extraction performance from all cooking zones.
- ✓ Space saving installation : For optimal use of space.
- ✓ emotionLight Pro – Highlight your hood with fully dimmable LED lights in a range of colours.
- ✓ iQdrive motor - The quiet, high-performance motor ensures efficient removal of odours and steam.
- ✓ cookConnect system: Use your hob to control your hood's power level and lighting.

### Features

#### Technical Data

Typology: .....	Downdraft
Length electrical supply cord: .....	130 cm
Required niche size for installation (HxWxD): .....	703mm x 781.0mm x 123mm mm
Net weight: .....	38.9 kg
Type of control: .....	Electronic
Number of speed settings: .....	3-stage + 2 intensive
Maximum output air extraction: .....	501 m³/h
Boost position output recirculating: .....	525 m³/h
Maximum output recirculating air: .....	416 m³/h
Boost position air extraction: .....	775 m³/h
Noise level: .....	62 dB(A) re 1pW
Diameter of air outlet: .....	150 mm
Grease filter material: .....	Washable stainless steel
Odour filter: .....	No
Operating Mode: .....	Convertible
Type of lamps used: .....	None
Grease filter type: .....	Kassette
Clean filter reminders: .....	Yes
Connection rating: .....	300 W
Fuse protection: .....	10 A
Voltage: .....	220-240 V
Frequency: .....	50; 60 Hz
Plug type: .....	Gardy plug w/ earthing
Installation typology: .....	Built-in
Body material: .....	Glass
Plug type: .....	Gardy plug w/ earthing
Dimensions of the product, with chimney (if exists) (in): .....	x x
Dimensions of the packed product: .....	24.01 x 44.88 x 34.25
Net weight: .....	86.000 lbs
Gross weight: .....	106.000 lbs
Motor location: .....	Integrated motor in hood body
No-return airflow flap: .....	No
Length electrical supply cord: .....	130 cm
Dimensions of the product, with chimney (if exists): .....	610x800x140 mm
Dimensions of the packed product (HxWxD): .....	610x1140x870 mm
Net weight: .....	38.9 kg
Gross weight: .....	48.1 kg



## iQ700, downdraft hood, 80 cm, clear glass, Black LD88WMM66

### Features

#### Variant

- 80 cm wide
- For installation in a kitchen cabinet
- The perfect unit (appliance) for installation in an island or Semi-island kitchen solution
- Suitable for ducted or re-circulated extraction
- For recirculated extraction Clean Air Plus recirculation kit (accessory) needed

#### Design

- The clear glass panel provides a glass edge lighting and is extendable via lift motor
- The appliance comes in an extraordinary glass design equipped with white edge lighting. Simply choose your favorite color via Homeconnect.
- For seamless worktop installation a special accessory is required
- Top Frame suitable for seamless installation to create a unity with cooktop for a pure surface design

#### Comfort

- Electronic controls via touchControl
- The user interface to the left provides extended functions
- The standard functions are located on the right-hand user interface
- touchControl control
- 3 speeds plus 2 intensive
- Automatic reset facility from intensive to normal setting
- Automatic revert setting, 6 minutes
- Automatic 10 minutes after running
- Air quality sensor
- Cooktop-based Hood Control (works with all Home Connect hobs)
- fully automatic hood

#### Features

- Activate Guided Air to guarantee nearly perfect extraction, regardless of pot height and pot position on the cooktop
- emotionLight Pro
- The high quality filter cassettes with integrated metal grease filters are dishwasher safe
- Metal grease filter, dishwasher safe
- Saturation indicator for grease filter and odor filter
- The filter service button automatically lifts filters into service position for easy removal
- The glass panel can be easily removed and cleaned

#### Connectivity

- Home Connect for connected home appliances and operation via smartphone or tablet (only in countries where Home Connect service is available)
- The Home Connect functionality can be extended by integrating numerous applications from external cooperation partners (partnerships)
- Voice Control enabled via popular voice assistants (only in countries where this service is available)

- interval function: available via Home Connect
- silence function: available via Home Connect

#### Performance

- Extraction rate according to EN 61591 ø 15 cm:
- max. Normal use 501m³/h
- Intensive 775 m³/h
- Extraction rate exhaust air according to EN 61591:
- max. normal use 501 m³/h, intensive 775 m³/h
- Noise level according to EN 60704-2-13 exhaust air:
- Max. normal use: 62dB(A) re 1 pW
- Intensive: 70 dB(A) re 1 pW
- Extraction rate according to EN 61591 ø 15 cm:
- max. Normal use 501m³/h
- Intensive 775 m³/h
- Max. exhaust air flow rate according to EN 61591: 775 m³/h
- Noise level according to EN 60704-2-13 at max. normal use exhaust air: Noise, max. speed in normal us: 62 dB dB(A) re 1 pW
- Noise min./max. Normal Level: 39/62 dB
- With the Clean Air Plus recirculation kit (available as optional accessory) your appliances reaches:
- Extraction rate in recirculation mode:
- Max. normal use: 416m³/h
- Intensive: 525m³/h
- Noise level in recirculation mode:
- Max. normal use: 65dB(A) re 1 pW
- Intensive: 70 dB(A) re 1 pW
- iQdrive Motor
- Max. extraction rate: 775 m³/h

#### Planning and installation information

- For seamless worktop installation a special accessory is required
- Suitable for installation into 90 cm cabinet
- Extension height 250 mm
- Dimensions (HxWxD): 709 x 812 x 140 mm
- Built-in dimensions (HxWxD): 703 mm x 781 mm x 123 mm
- 150 mm diameter pipe
- Electrical cable length 1.3 m
- For remote motor installation special accessory kit is needed
- Please reference the built-in dimensions provided in the installation drawing
- no combination with gas hobs allowed

#### Consumption Data

- Energy Efficiency Class: A (at a range of energy efficiency classes from A+++ to D)
- Average Energy Consumption: 36.9 kWh/year
- Blower Efficiency Class: A
- Lighting Efficiency Class: -
- Grease Filtering Efficiency Class: B

## Features

- Power rating: 300 W

\* In accordance with the EU-Regulation No 65/2014

Features

--	--

## iQ700, downdraft hood, 80 cm, clear glass, Black LD88WMM66

### Dimensioned drawings

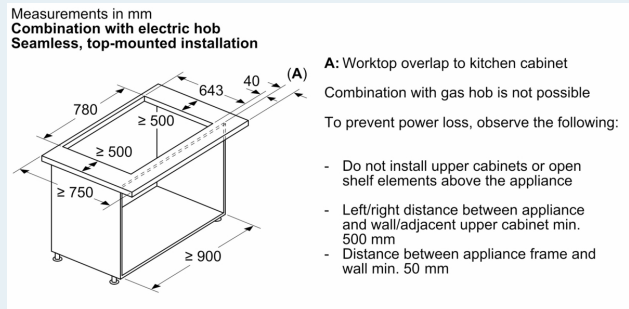
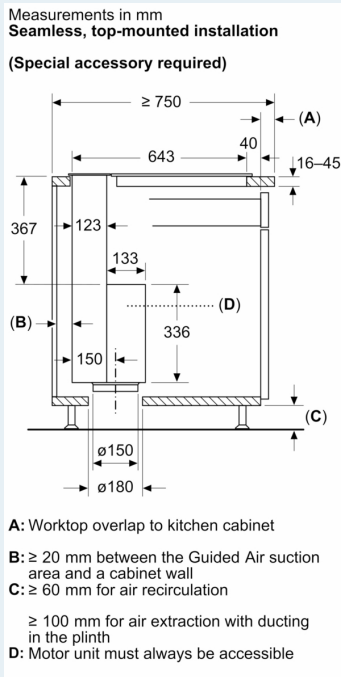
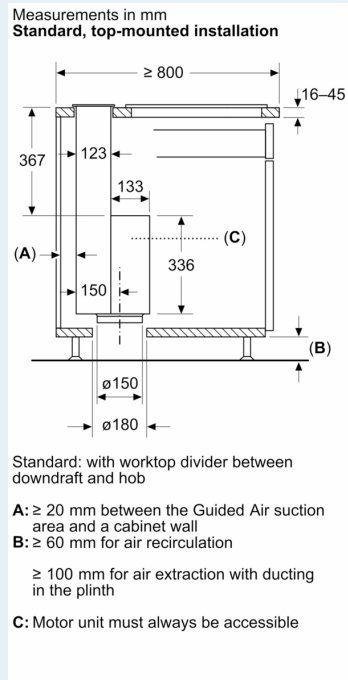
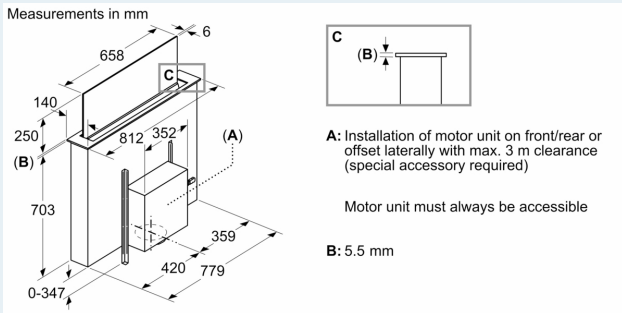

## Dimensioned drawings

### Measurements in mm Combination with electric hob Standard, top-mounted installation

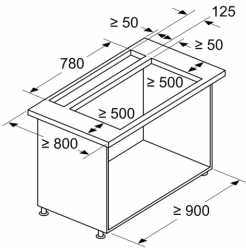

- Standard: with worktop divider between downdraft and hob
- Combination with gas hob is not possible
- To prevent power loss, observe the following:
- Do not install upper cabinets or open shelf elements above the appliance
  - Left/right distance between appliance and wall/adjacent upper cabinet min. 500 mm
  - Distance between appliance frame and wall min. 50 mm

### Planning recommendation, air recirculation

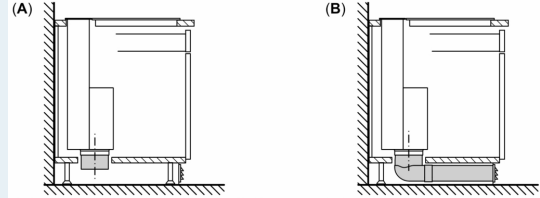

**A:** Exterior wall – U-value  $\leq 0.5 \text{ W}/(\text{m}^2\text{K})$

**B:** Exterior wall – U-value  $> 0.5 \text{ W}/(\text{m}^2\text{K})$

Standard installation: Partially laid around the toe kick

Installation with fully laid pipework to the toe kick for poorly insulated exterior walls or above cold floors

### Measurements in mm Standard, top-mounted installation

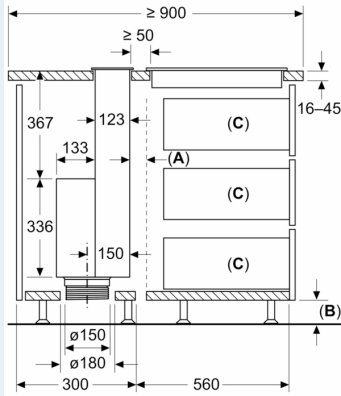

Standard: with worktop divider between downdraft and hob

- A:** Ventilation gap for hob
- B:**  $\geq 60 \text{ mm}$  for air recirculation  
 $\geq 100 \text{ mm}$  for air extraction with ducting in the plinth
- C:** Max. pull-out depth
- Motor unit must always be accessible

### Measurements in mm Seamless, top-mounted installation (Special accessory required)

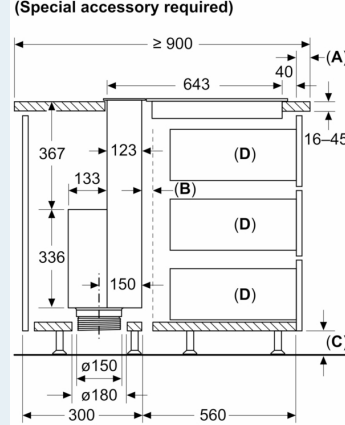

**A:** Worktop overlap to kitchen cabinet

- B:** Ventilation gap for hob
- C:**  $\geq 60 \text{ mm}$  for air recirculation  
 $\geq 100 \text{ mm}$  for air extraction with ducting in the plinth
- D:** Max. pull-out depth
- Motor unit must always be accessible