

iQ300, fully-integrated dishwasher, 45 cm, varioHinge for special installation situations SR73EX25ME



Optional accessories

SZ30BI02	decorative strips stainless steel 81,5cm
SZ34BI00	Built-in set 45 dishwashers, fully int.
SZ34CB00	Moveable cutlery basket
SZ38BI00	Connection rail for divided furniture
SZ72010	inlet and outlet hose extension 2 m
SZ73000	Dishwashing aid set
SZ73051EU	Mains cable with EU-Plug 5m
SZ73300	Wineglass-Tray

Excellent wifi-enabled dishwasher with program status projection on the floor, fitting even for special built-in situations and operable via smartphone or voice assistance.

- ✓ smartStart: Sync your dishwasher to prioritise either renewable energy or the lowest energy prices.
- ✓ autoOpen dry: Highly efficient drying by the automatic door opening.
- ✓ varioHinge: Our dishwasher that seamlessly complements your kitchen design.
- ✓ varioFlex baskets with varioDrawer: Our advanced basket system ensures efficient loading and organized cutlery storage.
- ✓ Short 60°: Turns a full load of normally soiled dishes into clean and dry ones in a very short time.

Features

Technical Data

Energy Efficiency Class (Regulation (EU) 2017/1369) ¹ :	B
Energy Consumption for 100 cycles Eco Programme ² :	.. 51 kWh/100 cycles
Maximum number of place settings:	10
The water consumption of the eco programme in liters per cycle ³ :	8.7 l
Programme duration ⁴ :	3:55 h
Airborne acoustical noise emissions :	44 dB(A) re 1pW
Airborne acoustical noise emission class:	B
Cleaning performance:	A
Water consumption:	8.7 l
Total annual water consumption 220 days:	1914 l
Design:	Built-in
Removable top:	No
Door panel options:	Not possible
Height of removable worktop:	0 mm
Height of the appliance:	815 mm
Adjustable feet:	Yes - all from front
Maximum adjustability feet:	60 mm
Adjustable plinth:	Both horizontal and vertical
Net weight:	32.2 kg
Gross weight:	33.8 kg
Connection rating:	2400 W
Fuse protection:	10 A
Voltage:	220-240 V
Frequency:	50; 60 Hz
Length electrical supply cord:	175 cm
Plug type:	Gardy plug w/ earthing
Length inlet hose:	165 cm
Length outlet hose:	205 cm
Hidden heating element:	Yes
Water protection system description:	Triple water protection 24h
Child safety devices:	No
Water softener:	Yes
Top basket type:	High flexibility with varioFlex basket
Adjustable upper basket:	Rackmatic 3-stage
Bottom basket type:	R3 45 cm
3rd Rack:	varioDrawer
Included accessories :	Vapor barrier plate
Number of place settings:	10
Dimensions of the packed product (HxWxD):	880x510x670 mm

¹ Scale of Energy Efficiency Classes from A to G

² Energy consumption in kWh per 100 cycles (in programme Eco 50 °C)

³ in programme Eco 50 °C

⁴ Duration of programme Eco 50 °C

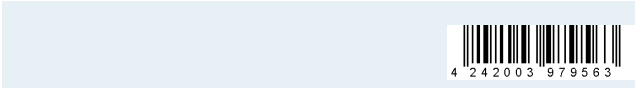

iQ300, fully-integrated dishwasher, 45 cm, varioHinge for special installation situations SR73EX25ME

Features

Efficiency & Performance

- Energy Efficiency Class¹: B
- Energy² / Water³: 51 kWh / 8.7 litres
- Capacity: 10 place settings
- Programme duration⁴: 3:55 (h:min)
- Noise level: 44 dB(A) re 1 pW
- Noise Efficiency Class: B

Programs

- 6 programmes: Eco 50 °C, Auto 45-65 °C, Intensive 70 °C, Speed 60 °C, Speed 45 °C, Favourite (Pre-Rinse)
- Favourite button
- 4 special options: Remote Start, Intensive Zone, HygienePlus, varioSpeed Plus
- Machine Care Programme
- Add-On functions via Home Connect app: Silence on Demand (Quiet now)

SIEMENS - Header 3

- autoOpen dry and Heat exchanger
- Aqua-Sensor
- dosageAssist
- iQdrive
- duoPower spray arms in top basket
- Self-cleaning filter system with 3-fold corrugated filter
- Interior tub material: Stainless Steel

Dimensions

- varioFlex basket system
- varioDrawer
- rackMatic height-adjustable top basket (3 stage)
- Low friction wheels on bottom basket
- Coloured anti-slip protection strips in top basket
- Rack Stopper to prevent derailing of bottom basket
- 2 foldable plate racks in top basket
- 2 foldable plate racks in bottom basket
- Cup shelf in top basket
- Cup shelf in bottom basket
- Glass rack in bottom basket

Display & Operation

- Home Connect enabled via WLAN
- Controls on top edge of door
- Panel legend: Plain text (english)
- infoLight (blue)
- Remaining programme time indicator (min)
- Acoustic end of cycle indicator
- Electronic delay timer: 1-24 hours

SIEMENS - Header 6

- aquaStop®: Siemens home appliances' warranty in case of water damage – for the lifetime of the appliance.*
- incl. varioHinge
- Glass care protection system

SIEMENS - Header 7

- incl. Salt filling funnel
- incl. Steam protection for worktop

SIEMENS - Header 8

- Product dimensions (HxWxD): 81.5 x 44.8 x 55 cm

¹ Scale of Energy Efficiency Classes from A to G

² Energy consumption in kWh per 100 cycles (in programme Eco 50 °C)

³ Water consumption in litres per cycle (in programme Eco 50 °C)

⁴ Duration of programme Eco 50 °C

* Please find warranty terms under [please insert here the local URL (internet address, e.g. <https://www.siemens-home.bsh-group.com> but with the direct page with the warranty terms)

iQ300, fully-integrated
dishwasher, 45 cm, varioHinge for
special installation situations
SR73EX25ME

Dimensioned drawings

measurements in mm

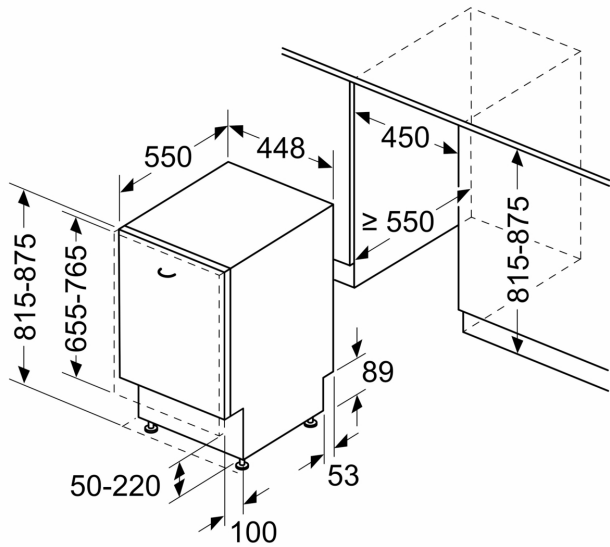

measurements in mm

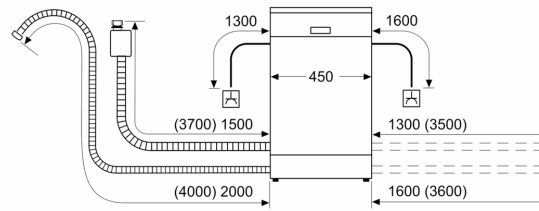

⏏ socket
() values with extension kit